

**SIEMENS**

SIEMENS AKTIENGESELLSCHAFT

T-43-25

**Transistor Array with 5 NPN Transistors**

TCA 671  
TCA 871  
TCA 971  
TCA 991  
Bipolar IC

**Features**

- Versatile use
- Slight  $V_{BE}$  and  $B$  deviations
- High output current
- Good thermal matching
- TCA 971; G/TCA 991; G compatible with 3045/46/86 and 3146

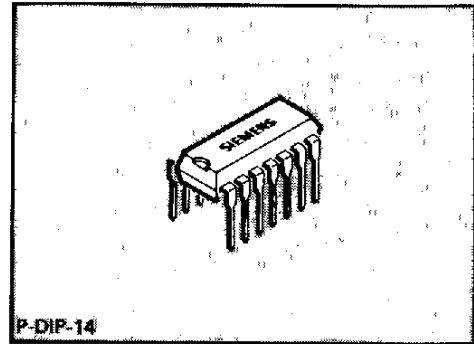

4

Type	Ordering Code	Package
STCA 671	Q67000-T1	P-DIP-14
STCA 671 G	Q67000-A2366	P-DSO-14 (SMD)
STCA 871	Q67000-T2	P-DIP-14
STCA 871 G	Q67000-A2367	P-DSO-14 (SMD)
STCA 971	Q67000-T11	P-DIP-14
STCA 971 G	Q67000-A8075	P-DSO-14 (SMD)
STCA 991	Q67000-T12	P-DIP-14
STCA 991 G	Q67000-A8076	P-DSO-14 (SMD)

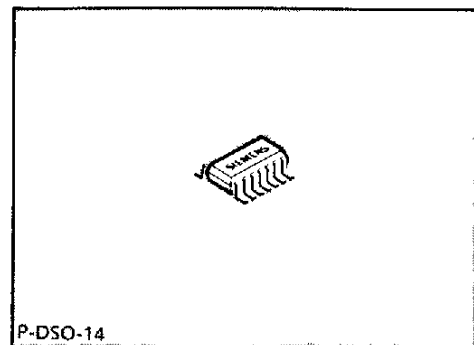

TCA 671, TCA 871, TCA 971, and TCA 991 are monolithic integrated transistor arrays each consisting of five NPN transistors. The arrays are well suited for switching and amplifying applications up to approx. 30 MHz. Due to a uniform design, the transistor characteristics show only slight deviations. The arrays are preferably intended for lamp drivers, amplifiers, pulse generators, and types TCA 971 and TCA 991 especially for discrete differential amplifiers.

**Pin Configurations**

(top view)

TCA 671, TCA 871  
TCA 971, TCA 991

substrate = pin 3  
substrate = pin 13

TCA 671 G, TCA 871 G,  
TCA 971 G, TCA 991 G

Substrate connection has to be on the most negative potential.

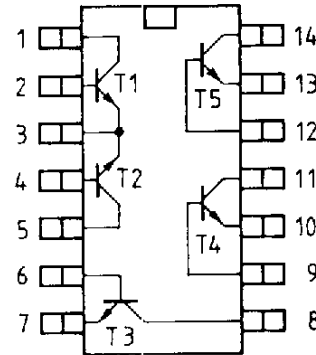
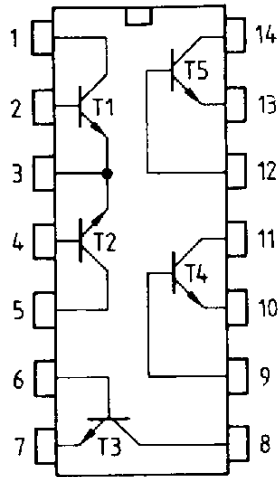

**Test Circuit for Switching Times**

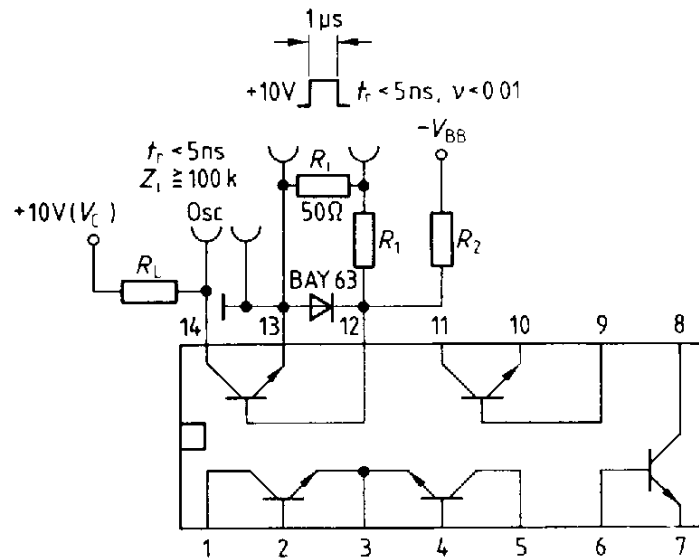

**Switching Times**

$I_C : I_{B1} : -I_{B2} \approx 10 : 1 : 1 \text{ mA}$ ;  $R_1 = 5 \text{ k}\Omega$ ;  $R_2 = 5 \text{ k}\Omega$ ;  $V_{BB} = 3.5 \text{ V}$ ;  $R_L = 990 \Omega$   
 $t_{ON} 85 (< 150) \text{ ns}$      $t_{OFF} 480 (< 800) \text{ ns}$

$I_C : I_{B1} : -I_{B2} \approx 100 : 10 : 10 \text{ mA}$ ,  $R_1 = 500 \Omega$ ;  $R_2 = 700 \Omega$ ,  $V_{BB} = 5 \text{ V}$ ;  $R_L = 98 \Omega$   
 $t_{ON} 55 (< 150) \text{ ns}$      $t_{OFF} 450 (< 800) \text{ ns}$

**Absolute Maximum Ratings**

Parameter	Symbol	Limit Values		Unit
		TCA 671 TCA 971	TCA 871 TCA 991	
Collector-base breakdown voltage	$V_{CB0}$	45	35	V
Collector-emitter breakdown voltage	$V_{CE0}$	42	32	V
Emitter-base breakdown voltage	$V_{EB0}$	6	6	V
Collector-substrate voltage ( $I_C = 100 \mu\text{A}$ )	$V_{CS}$	70	60	V
Collector current	$I_C$	200	200	mA
Base current	$I_B$	10	10	mA
Permissible power dissipation for a single transistor	$P_{tot}$	300	300	mW
Junction temperature	$T_j$	150	150	$^{\circ}\text{C}$
Storage temperature range	$T_{stg}$	-40 to 125	-40 to 125	$^{\circ}\text{C}$
Thermal resistance system - air	$R_{th SA}$	85	85	K/W
TCA 671 G; TCA 871 G; TCA 971 G; TCA 991 G	$R_{th SA}$	145	145	K/W

4

**Operating Range**

Ambient temperature	$T_A$	-25 to 85	-25 to 85	$^{\circ}\text{C}$
---------------------	-------	-----------	-----------	--------------------

**Characteristics** $T_A = 25^{\circ}\text{C}$ 

Parameter	Symbol	Limit Values TCA 671 TCA 971			Limit Values TCA 871 TCA 991			Unit
		min.	typ.	max.	min.	typ.	max.	
Differential base current for transistors T1 = T2 at $V_{CE} = 3 \text{ V}$ , $I_C = 1 \text{ mA}$	$I_{BD}$		0.5	1		1		$\mu\text{A}$
Base-emitter voltage at $V_{CE} = 3 \text{ V}$ , $I_C = 1 \text{ mA}$	$V_{BE}$		0.65			0.65		V
Differential base-emitter voltage for transistors T1 + T2 at $V_{CE} = 3 \text{ V}$ , $I_C = 1 \text{ mA}$	$V_{BED}$		2	5		4		mV
Differential base-emitter voltage for transistors T3 to T5 at $V_{CE} = 3 \text{ V}$ , $I_C = 1 \text{ mA}$	$V_{BED}$		4	10		6		mV
Temperature coefficient of base-emitter voltage at $V_{CE} = 3 \text{ V}$ , $I_C = 1 \text{ mA}$	$\frac{\Delta V_{BE}}{\Delta T}$		-2			-2		mV/K
Transition frequency	$f_T$	300	550		300	550		MHz

**Characteristics** $T_A = 25^\circ\text{C}$ 

Parameter	Symbol	Limit Values TCA 671 TCA 971			Limit Values TCA 871 TCA 991			Unit
		min.	typ.	max.	min.	typ.	max.	
Collector-base breakdown voltage at $I_C = 100\ \mu\text{A}$ , $I_E = 0$	$V_{CB0}$	45			35			V
Collector-emitter breakdown voltage at $I_C = 100\ \mu\text{A}$ , $I_B = 0$	$V_{CE0}$	42			32			V
Collector-substrate breakdown voltage at $I_C = 100\ \mu\text{A}$ , $I_{CS} = 0$	$V_{CS}$	70			60			V
Emitter-base breakdown voltage at $I_E = 100\ \mu\text{A}$ , $I_C = 0$	$V_{EB0}$	6			6			V
Collector-emitter saturation voltage at $I_C = 50\ \text{mA}$ ; $I_B = 5\ \text{mA}$	$V_{CE\text{ Sat}}$		200	350		200	350	mV
Collector-base cutoff current at $V_{CB} = 25\ \text{V}$ , $I_E = 0$	$I_{CB0}$		0.02	1		0.02	10	$\mu\text{A}$
Collector-emitter cutoff current at $V_{CE} = 25\ \text{V}$ , $I_B = 0$	$I_{CE0}$			1			10	$\mu\text{A}$
Static current gain at $V_{CE} = 3\ \text{V}$ , $I_C = 100\ \mu\text{A}$	$B$	40	80		40	80		
at $V_{CE} = 3\ \text{V}$ , $I_C = 1\ \text{mA}$		100	140		100	140		
at $V_{CE} = 3\ \text{V}$ , $I_C = 10\ \text{mA}$		100	160		100	160		
at $V_{CE} = 3\ \text{V}$ , $I_C = 100\ \text{mA}$		40	100		40	100		

**Current gain versus collector current**  
 $V_{CE} = 3\text{ V}, T_A = 25^\circ\text{C}$

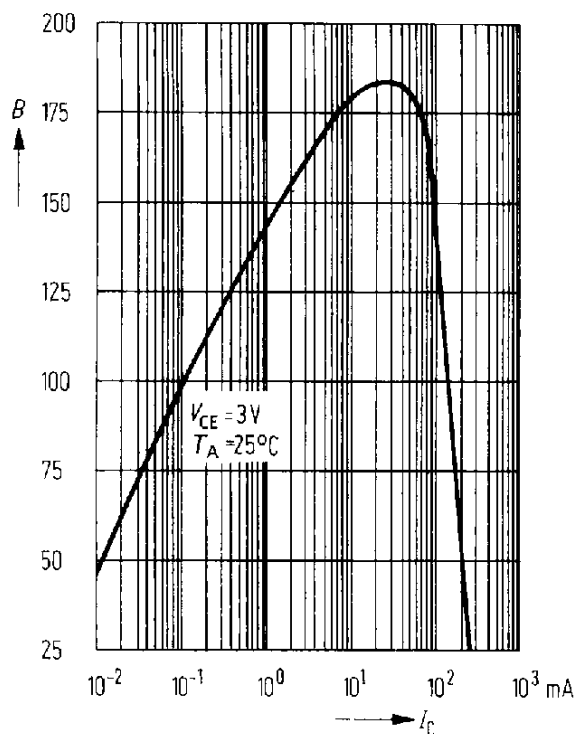

**Transition frequency versus collector current**  
 $V_{CE} = 3\text{ V}, T_A = 25^\circ\text{C}$

T-43-25

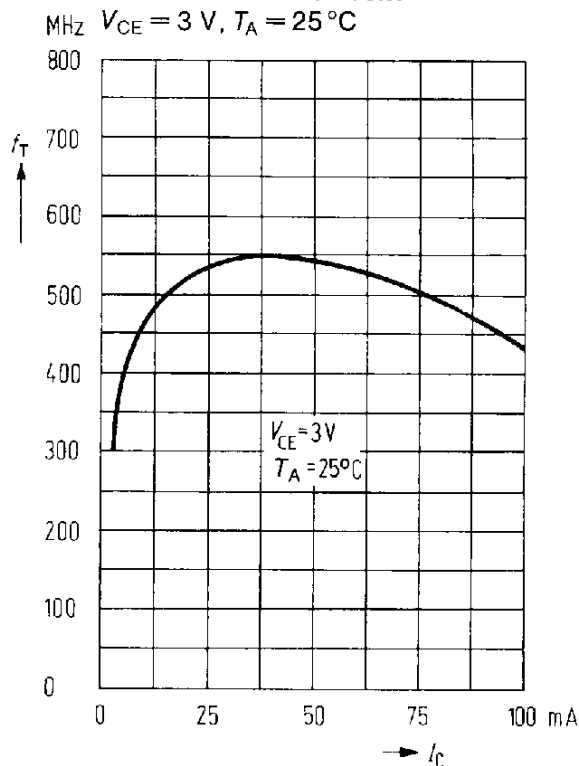

4

**Collector-emitter saturation voltage versus collector current**  
 $B = 20$

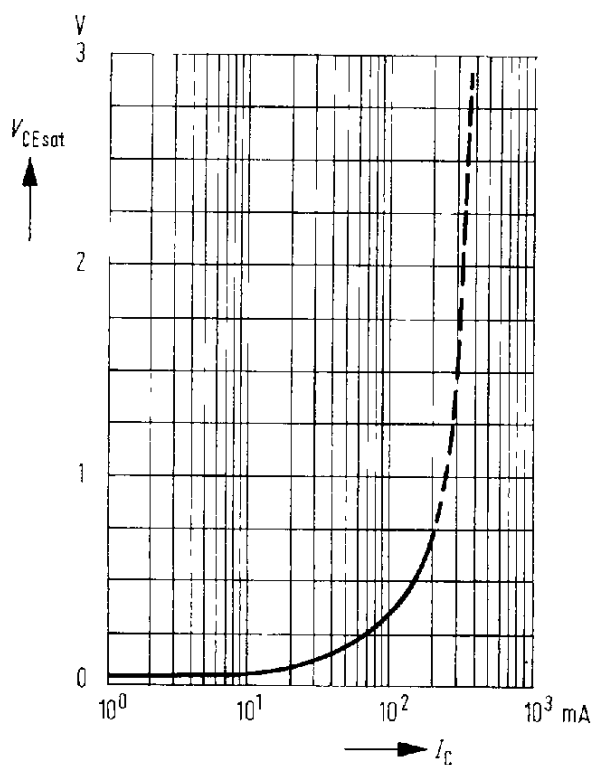

**Base-emitter voltage versus input current**  
 $V_{CE} = 3\text{ V}; T_A = 25^\circ\text{C}$

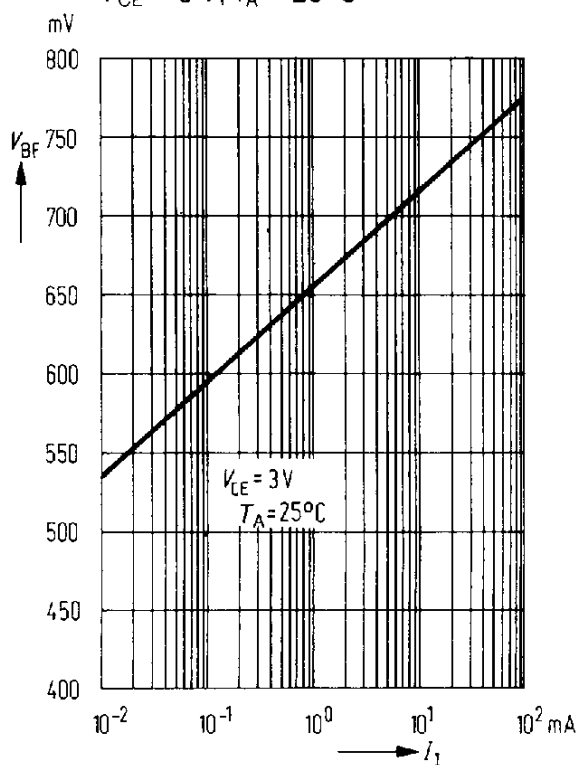

**Output characteristics**  
Collector current versus  
collector-emitter voltage

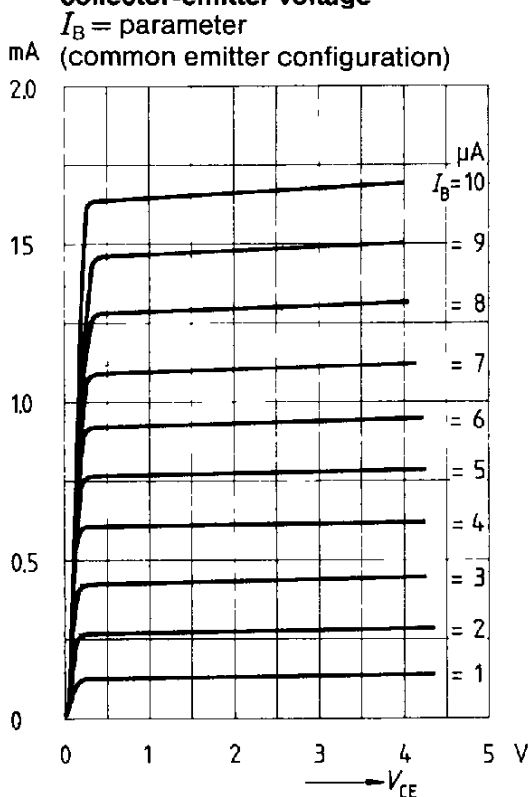

**Output characteristics**  
Collector current versus  
collector-emitter voltage

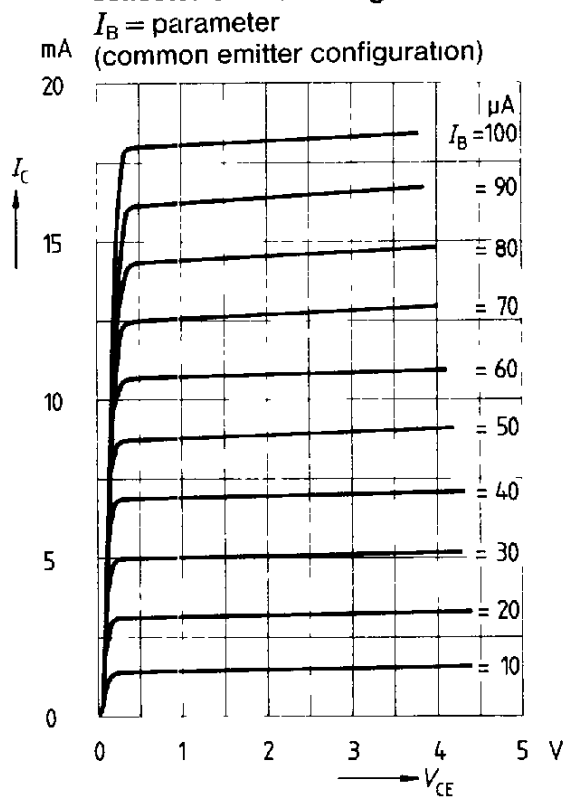

**Output characteristics**  
Collector current versus  
collector-emitter voltage

