

TDA 4282 T Quasi-Parallel Sound IC with FM IF, Sym. Input and Volume Control

The TDA 4282 T is a controlled AM amplifier with FM demodulator (to produce an intercarrier) and subsequent sound-IF limiting amplifier with coincidence demodulator, standard VCR connection and separate AF-output with volume control.

- Outstanding limiting qualities
- Connection for video recorder
- Little external circuitry

Maximum ratings

Supply voltage	V_S	15	V
$t \leq 1 \text{ min}$	V_S	16.5	V
Thermal resistance (system-ambient air)	$R_{th SA}$	65	K/W
Junction temperature	T_j	150	°C
Storage temperature	T_{stg}	-40 to 125	°C

Operational range

Supply voltage	V_S	11 to 15	V
Frequency range AM part	f_{AM}	10 to 60	MHz
FM part	f_{FM}	0.01 to 12	MHz
Control voltage AM part	V_2	0 to 5	V
Switch current FM part	I_B	0.3 to 1	mA
Ambient temperature in operation	T_{amb}	0 to 60	°C

Characteristics ($V_S = 15V, T_{amb} = 25^\circ C$)

	min	typ	max	
Current consumption				
AM-part:				
AGC-range		60	80	mA
AGC-voltage	0	55	5	dB
Input resistance		10		V
Input impedance at max. gain		1.8/2		k Ω
at min. gain		1.9/0		k Ω /pF
Output resistance		500		k Ω /pF
		500		Ω
		500		Ω
FM-part: ($f_z = 5.5$ MHz; $f_{mod} = 1$ kHz)				
Input impedance		800		Ω
AM-suppression		42		dB
($V_{i9-10} = 1$ mV; $f = 12.5$ MHz; $m = 30\%$)				
Signal-to-noise ratio ($V_{i9-10} = 10$ mV)		85		dB
Input voltage for limiting		60		μ V
($\Delta f = 30$ kHz)				
Demodulator output resistance		5.4		k Ω
Output resistance for VCR-recording			500	Ω
Input resistance for VCR-playback	10			k Ω
Integrated resistor for deemphasis		10		k Ω
AF-output voltage		600		mV _{rms}
($V_i = 10$ mV; with CDA 5.5 MC 10, $R_{q11} = 2.9$ Ω)				
($\Delta f = 12.5$ kHz)	260	300		mV _{rms}
AF-gain during VCR-playback		0.5		
Total harmonic distortion		1		%
Cross talk ($V_i = 1$ mV)				
$V_{12} = 2 V_{rms}$	50	52		dB
$V_{12} = 0.3 V_{rms}$	60	65		dB
Range of volume control	70	85		dB

Circuit description

The TDA 4282 T contains essentially two functional blocks:

1. A regulated AM amplifier with a peak rectifier to generate the AGC voltage. The AM amplifier drives an FM demodulator, at the output of which the differential sound carrier (38.9 MHz–33.4 MHz = 5.5 MHz) is available. The double sideband portions close to the carrier are suppressed. The 5.5 MHz carrier reaches the functional block via an external selection.
2. An FM limiter amplifier with coincidence demodulator, a standard VCR connector and a separate AF output with volume control.

Pin assignment

Pin No.	Pin designation
1	Ground
2	AM-IF control
3	AM amplifier demodulator
4	AM amplifier demodulator
5	Supply voltage (plus)
6	AM amplifier sound carrier output TT 1
7	AM amplifier sound carrier output TT 2
8	AM-IF amplifier negative feedback for working point
9	AM-IF amplifier negative feedback for working point
10	FM-IF amplifier IF input
11	AF output
12	VCR connection
13	FM-IF amplifier emitter follower output
14	FM-IF amplifier emitter follower output
15	FM amplifier demodulator
16	FM amplifier demodulator
17	Deemphasis condensator
18	Volume control
19	AM-IF negative feedback for working point
20	AM-IF amplifier IF input
21	AM-IF amplifier IF input
22	AM-IF negative feedback amplifier for working point

Block diagram and test circuit

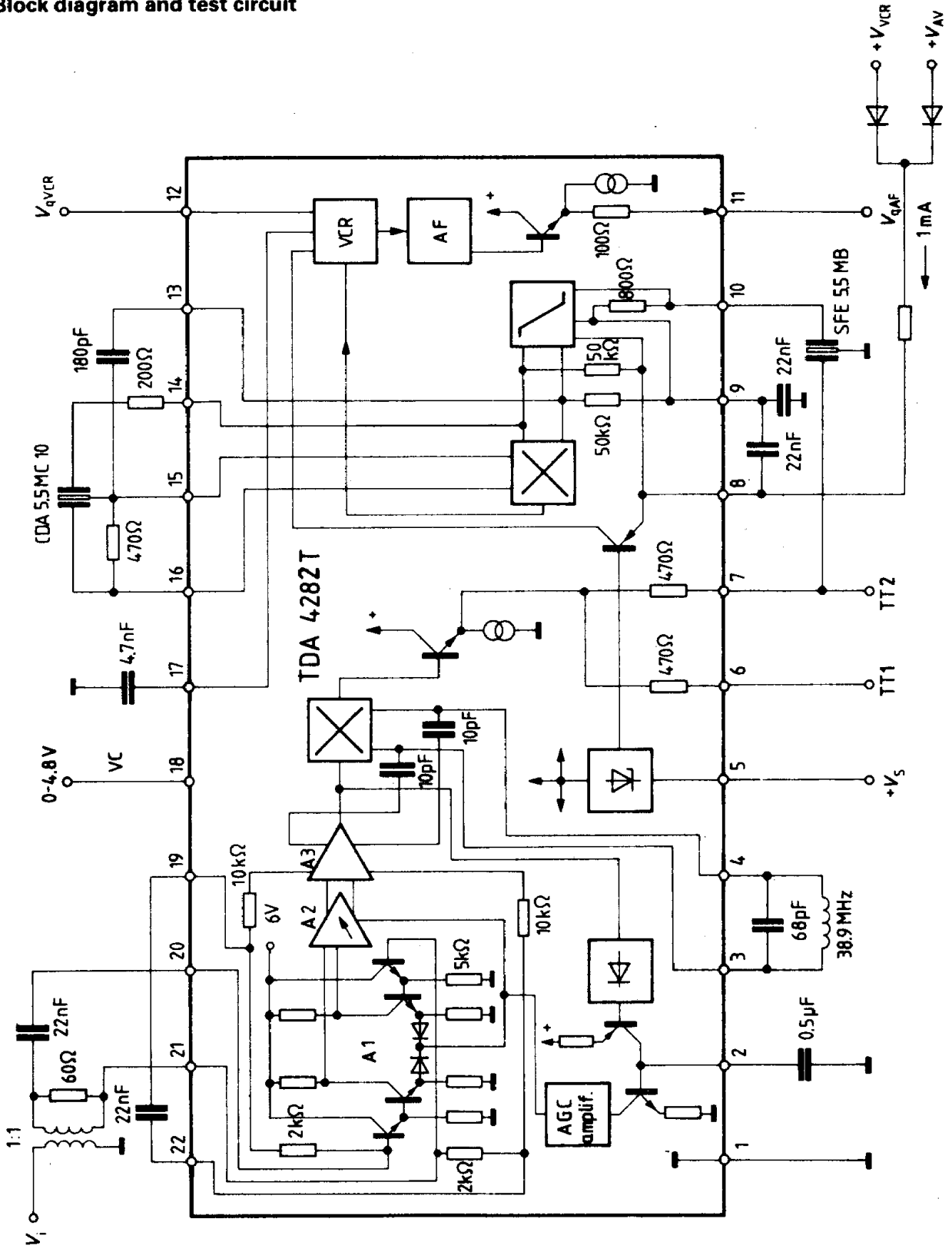

Application circuit

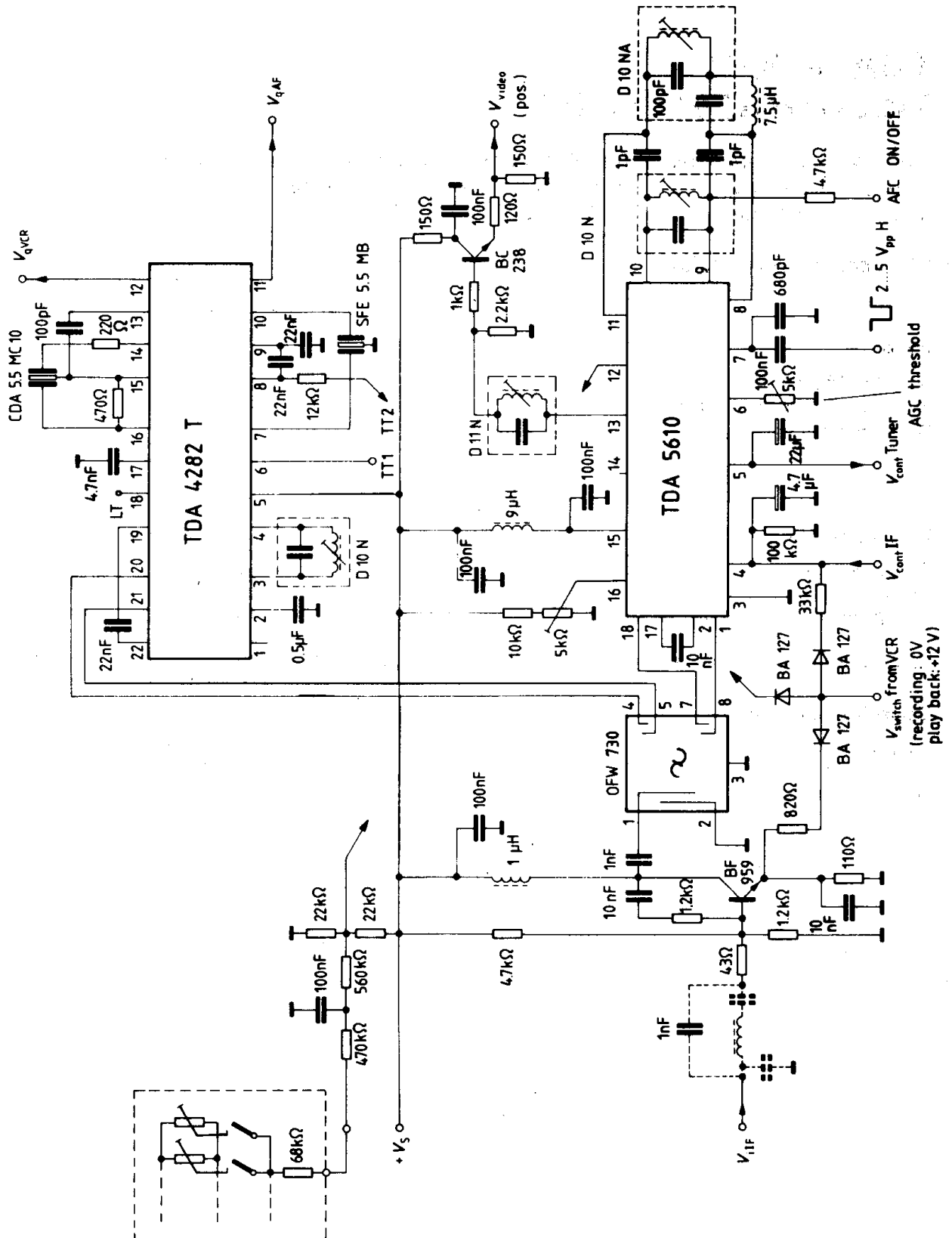

7