

**NPN Silicon Darlington Power Transistor**

**BUX 28**

SIEMENS AKTIENGESELLSCHAFT

Not for new design

BUX 28 is a triple diffused monolithic NPN darlington power transistor in TO 3 case (3 A 2 DIN 41872). The collector is electrically connected to the case. The resistor between base and emitter as well as the inverting diode are integrated.

BUX 28 is particularly suitable for use in firing circuits of cars and for general purpose switching applications at high voltages.

Type	Ordering code
BUX 28	Q62702-U258
Mica washer	Q62901-B11-A
Insulating nipple	Q62901-B50

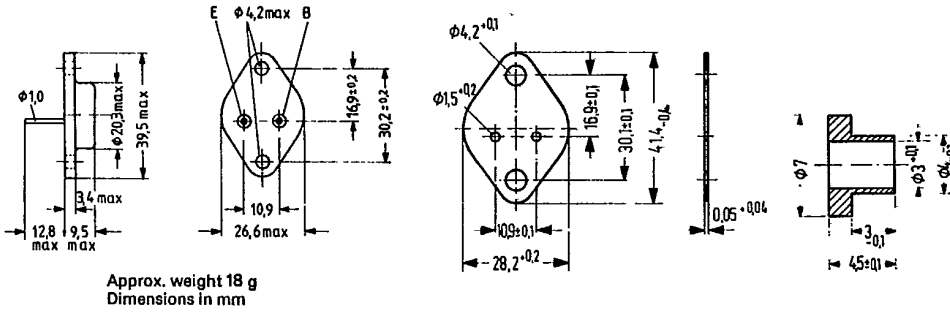
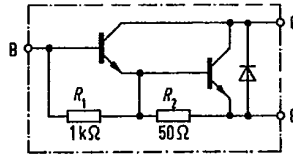

Approx. weight 18 g  
Dimensions in mm

Mica washer dry:  $R_{th} = 1.25 \text{ K/W}$   
greased:  $R_{th} = 0.35 \text{ K/W}$

Insulating nipple

**Maximum ratings**

Collector-emitter voltage	$V_{CEO}$	350	V
Collector-emitter voltage	$V_{CER}$	350	V
Collector current	$I_C$	8	A
Collector peak current ( $t_p < 1 \text{ ms}$ )	$I_{CM}$	12	A
Current of the inverse diode	$-I_C$	8	A
Base current	$I_B$	1.5	A
Junction temperature	$T_j$	175	°C
Total power dissipation ( $T_{case} \leq 55 \text{ °C}$ )	$P_{tot}$	80	W

**Thermal resistance**

Junction to case	$R_{thJC}$	< 1.2	K/W
------------------	------------	-------	-----

**Static characteristics ( $T_{case} = 25^{\circ}C$ )**

Collector-emitter breakdown voltage  
 ( $I_C = 100\text{ mA}; L = 25\text{ mH}$ )  
 Collector cutoff current  
 Collector cutoff current  
 ( $V_{CE} = 350\text{ V}$ )  
 ( $V_{CE} = 350\text{ V}; T_{case} = 125^{\circ}C; t_p < 200\text{ }\mu\text{s}$ )  
 DC current gain  
 ( $I_C = 7\text{ A}; V_{CE} = 1.5\text{ V}$ )  
 Collector-emitter saturation voltage  
 ( $I_C = 10\text{ A}; I_B = 0.25\text{ A}$ )  
 Base-emitter saturation voltage  
 ( $I_C = 10\text{ A}; I_B = 0.25\text{ A}$ )  
 Forward voltage of the inverse diode  
 ( $-I_C = 7\text{ A}; I_B = 0$ )

$V_{(BR)CEO}$	> 350	V*
$I_{CEO}$	< 1	mA
$I_{CE0}$	< 1	mA
$I_{CES}$	< 10	mA
$h_{FE}$	> 10	-
$V_{CEsat}$	< 2	V*
$V_{BEsat}$	< 2.4	V*
$-V_{CE}$	1.5	V

\* AQL = 0.65%

