

Silicon NPN Power Transistor

BUF405AXI

DESCRIPTION

- High Voltage
- High Speed Switching

APPLICATIONS

- Designed for high reliability industrial and professional power driving applications such as motor drivers and off-line switching power supplies.

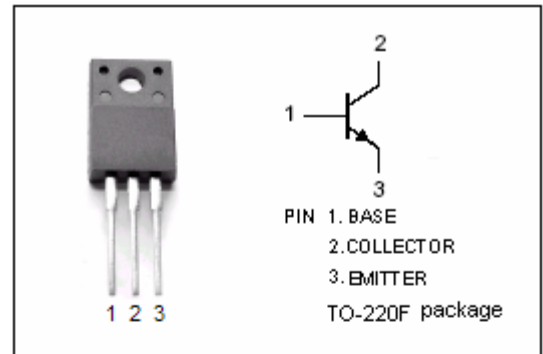

ABSOLUTE MAXIMUM RATINGS (T_a=25)

SYMBOL	PARAMETER	VALUE	UNIT
V _{CEV}	Collector-Emitter Voltage V _{BE} = -1.5V	1000	V
V _{CEO}	Collector-Emitter Voltage	450	V
V _{EBO}	Emitter-Base Voltage	7	V
I _C	Collector Current-Continuous	7.5	A
I _{CM}	Collector Current-Peak	15	A
I _B	Base Current-Continuous	3	A
I _{BM}	Base Current-peak	4.5	A
P _C	Collector Power Dissipation @T _C =25	39	W
T _j	Junction Temperature	150	
T _{stg}	Storage Temperature Range	-65~150	

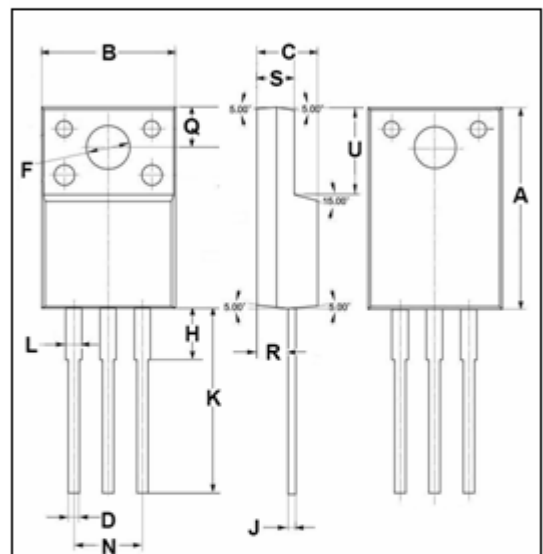

DIM	mm	
	MIN	MAX
A	14.95	15.05
B	10.00	10.10
C	4.40	4.60
D	0.75	0.80
F	3.10	3.30
H	3.70	3.90
J	0.50	0.70
K	13.4	13.6
L	1.10	1.30
N	5.00	5.20
Q	2.70	2.90
R	2.20	2.40
S	2.65	2.85
U	6.40	6.60

THERMAL CHARACTERISTICS

SYMBOL	PARAMETER	MAX	UNIT
R _{th j-c}	Thermal Resistance, Junction to Case	3.2	/W

Silicon NPN Power Transistor

BUF405AXI

ELECTRICAL CHARACTERISTICS

 $T_C=25$ unless otherwise specified

SYMBOL	PARAMETER	CONDITIONS	MIN	TYP.	MAX	UNIT
$V_{CEO(SUS)}$	Collector-Emitter Sustaining Voltage	$I_C= 0.2A; I_B= 0; L= 25mH$	450			V
$V_{(BR)EBO}$	Emitter-Base Breakdown Voltage	$I_E= 50mA; I_C= 0$	7			V
$V_{CE(sat)-1}$	Collector-Emitter Saturation Voltage	$I_C= 2.5A; I_B= 0.25A$		0.8		V
$V_{CE(sat)-2}$	Collector-Emitter Saturation Voltage	$I_C= 5A; I_B= 1A$		0.5		V
$V_{BE(sat)-1}$	Base-Emitter Saturation Voltage	$I_C= 2.5A; I_B= 0.25A$		0.9		V
$V_{BE(sat)-2}$	Base-Emitter Saturation Voltage	$I_C= 5A; I_B= 1A$		1.1		V
I_{CER}	Collector Cutoff Current	$V_{CE}= V_{CEV}; R_{BE}= 5$ $V_{CE}= V_{CEV}; R_{BE}= 5 ; T_C=100$			0.1 0.5	mA
I_{CEV}	Collector Cutoff Current	$V_{CE}= V_{CEV}; V_{BE}= -1.5V$ $V_{CE}= V_{CEV}; V_{BE}= -1.5V; T_C=100$			0.1 0.5	mA
I_{EBO}	Emitter Cutoff Current	$V_{EB}= 5V; I_C= 0$			1.0	mA

Switching Times

t_s	Storage Time	$I_C= 2.5A; I_{B1}= 0.25A; V_{CC}= 50V;$ $V_{BB}= -5V, R_{BB}= 2.4 ; L= 1mH$ $V_{clamp}= 400V$		0.8		μs
t_f	Fall Time			0.05		μs