

TA7523S

SINGLE COMPARATOR

TA7523S is comparator with wide range single or two supply voltage. Output is open collector and wired-OR possible.

FEATURES

- Wide Common Mode Input Voltage : $0V \sim V_{CC} - 1.5V$
- Output is Compatible with TTL and CMOS.
- With Two Output Terminal (OUT, \overline{OUT})
- Hysteresis Voltage Width is Variable by External Resistor.
- Wide Supply Voltage Range : $2V \sim 36V$ or $\pm 1V \sim \pm 18V$

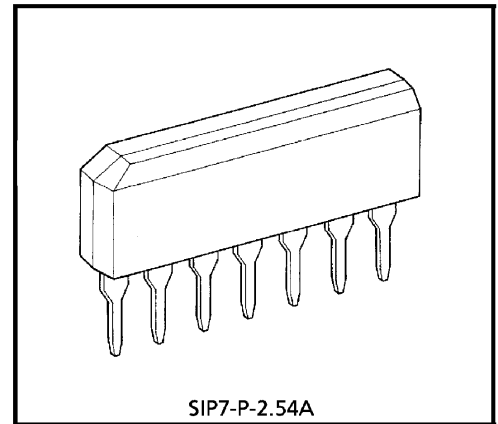

SIP7-P-2.54A

Weight : 0.7g (Typ.)

PIN CONNECTION

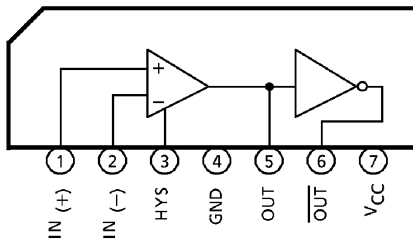

EQUIVALENT CIRCUIT

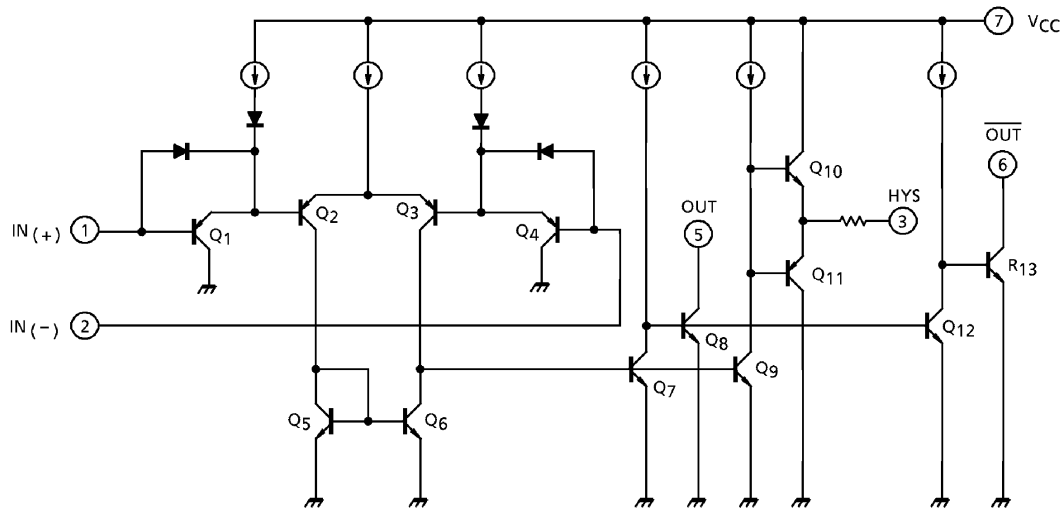

MAXIMUM RATINGS (Ta = 25°C)

CHARACTERISTIC	SYMBOL	RATING	UNIT
Supply Voltage	V _{CC}	± 18 or 36	V
Differential Input Voltage	DV _{IN}	± 36	V
Common Mode Input Voltage	CMV _{IN}	- 0.3~V _{CC}	V
Power Dissipation	P _D	500	mW
Operating Temperature	T _{opr}	- 40~85	°C
Storage Temperature	T _{stg}	- 55~125	°C

ELECTRICAL CHARACTERISTICS (V_{CC} = 5V, Ta = 25°C)

CHARACTERISTIC	SYMBOL	TEST CIR-CUIT	TEST CONDITION	MIN.	TYP.	MAX.	UNIT
Input Offset Voltage	V _{IO}	4	—	—	3	7	mV
Input Bias Current	I _I	2	—	—	25	250	nA
Input Offset Current	I _{IO}	2	—	—	5	50	nA
Common Mode Input Voltage	CMV _{IN}	4	—	0	—	V _{CC} - 1.5	V
Voltage Gain	G _V	—	R _L = 15kΩ	—	200	—	V/mV
Supply Current	I _{CC}	1	No Load	—	0.5	3	mA
Sink Current	I _{SINK}	5	IN (+) = 0V, IN (-) = 1V, V _{OL} = 1.5V	6	16	—	mA
Output Voltage	V _{OL}	5	IN (+) = 0V, IN (-) = 1V, I _{SINK} = 3mA	—	0.2	0.4	V
Output Leak Current	I _{LEAK}	3	IN (+) = 1V, IN (-) = 0V, V _O = 5V	—	0.1	—	nA
Response Time	t _{rsp}	6	R _L = 5.1kΩ, C _L = 15pF	—	1.3	—	μs

TEST CIRCUIT

(1) I_{CC}

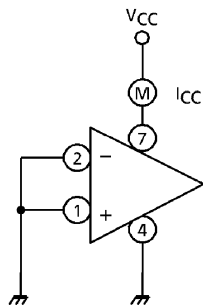

(2) I_I, I_{IO}

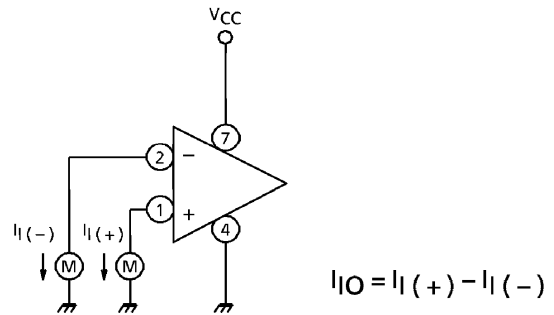

(3) I_{LEAK}

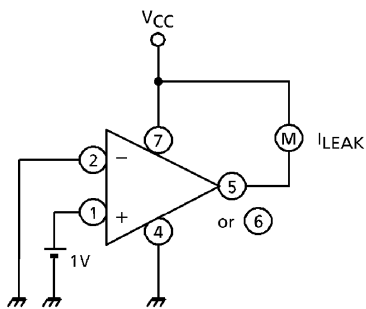

(4) V_{IO}, CMV_{IN}

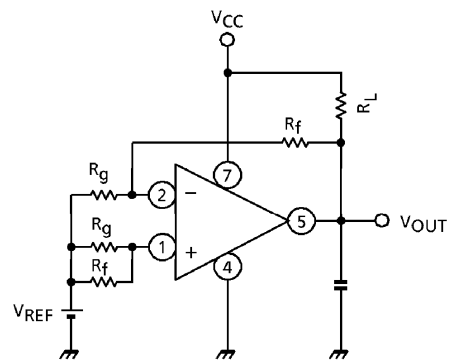

(5) I_{sink}, V_{OL}

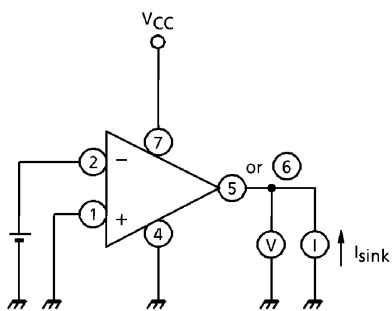

(6) t_{rsp}

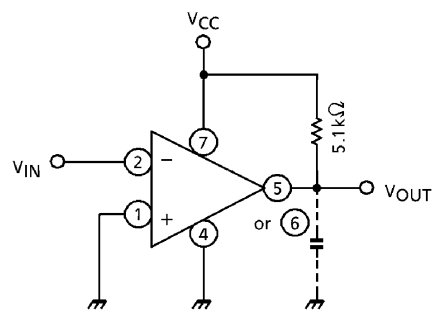

APPLICATION CIRCUIT

1. GENERAL COMPARATOR

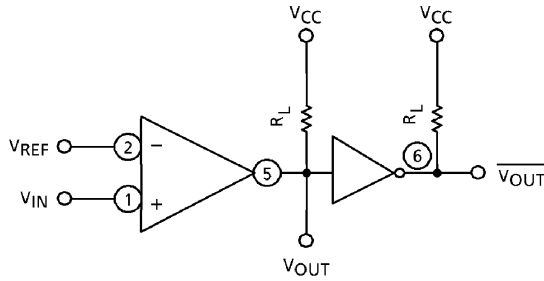

2. COMPARE WITH INPUT VOLTAGE

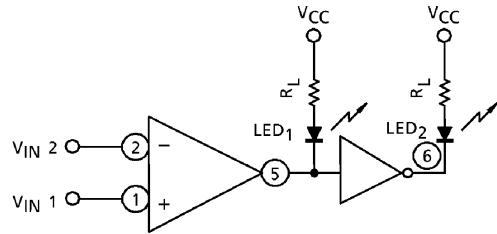

LED₂ IS LIGHTED AT V_{IN 1} > V_{IN 2}
 LED₁ IS LIGHTED AT V_{IN 1} < V_{IN 2}

3. COMPARATOR WITH HYSTERESIS

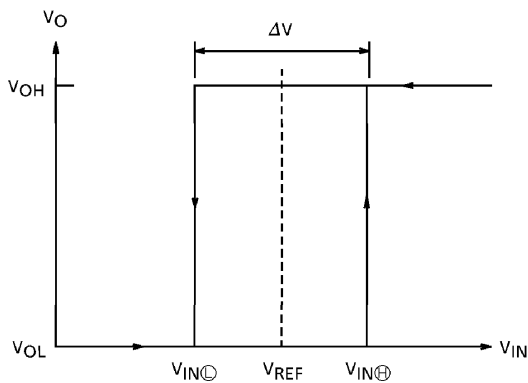
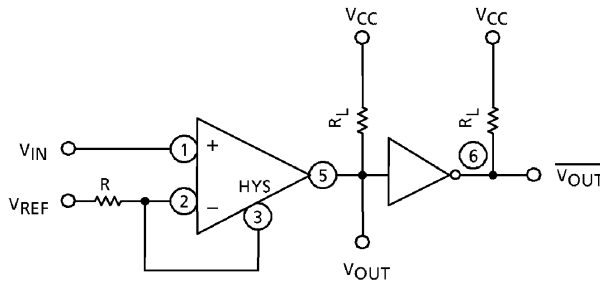

- VOH : OUTPUT VOLTAGE ("H" LEVEL)
- VOL : OUTPUT VOLTAGE ("L" LEVEL)
- VIN⊕ : TURNOVER INPUT VOLTAGE ("H" LEVEL)
- VIN⊖ : TURNOVER INPUT VOLTAGE ("L" LEVEL)
- VREF : REFERENCE VOLTAGE
- ΔV : HYSTERESIS WIDTH

Calculate the Hysteresis width using the following equation

$$\Delta V \doteq (V_{CC} - 2) \frac{R}{R + 10} \quad V_{CC} (V) \quad R (k\Omega)$$

CHARACTERISTICS

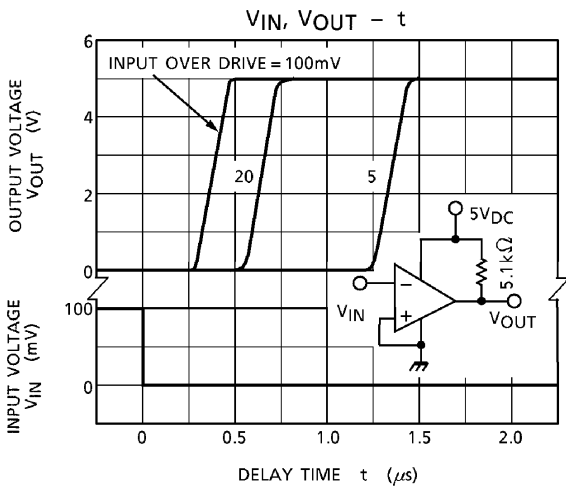
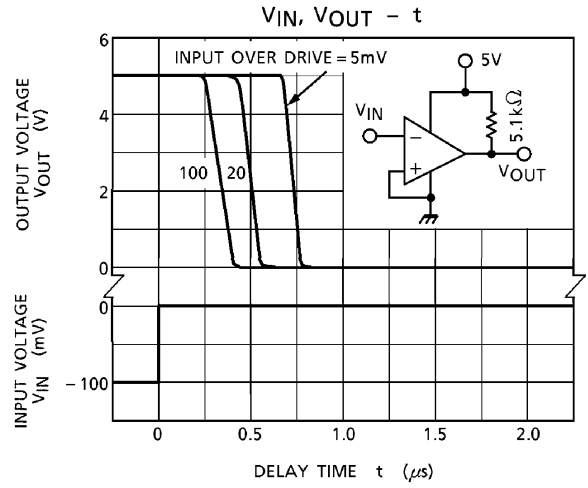
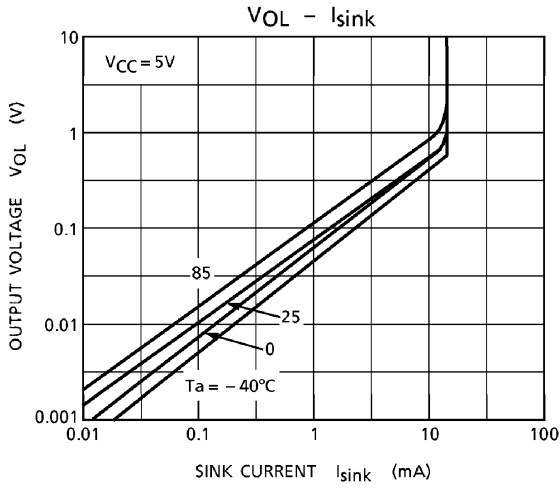
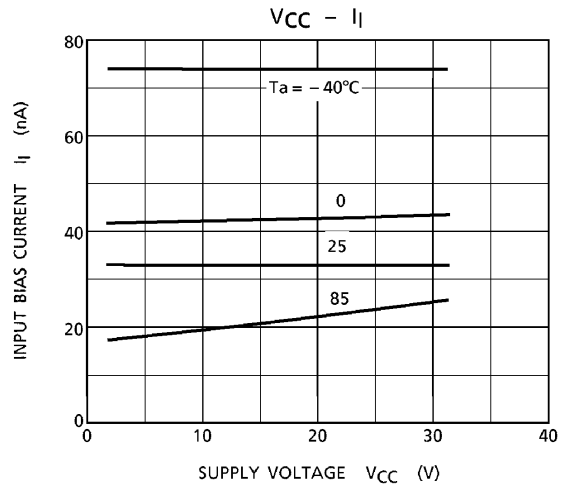
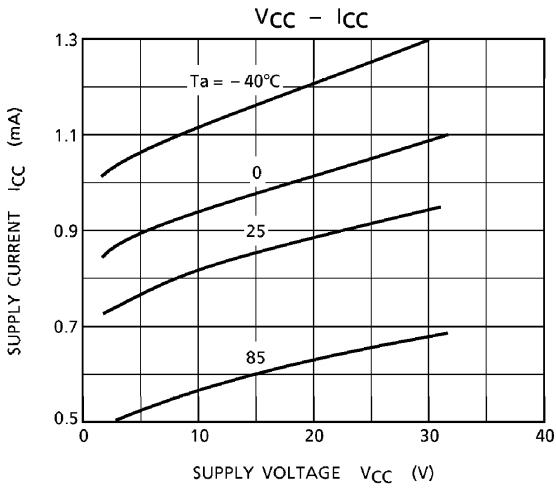

PACKAGE DIMENSIONS
SIP7-P-2.54A

Unit : mm

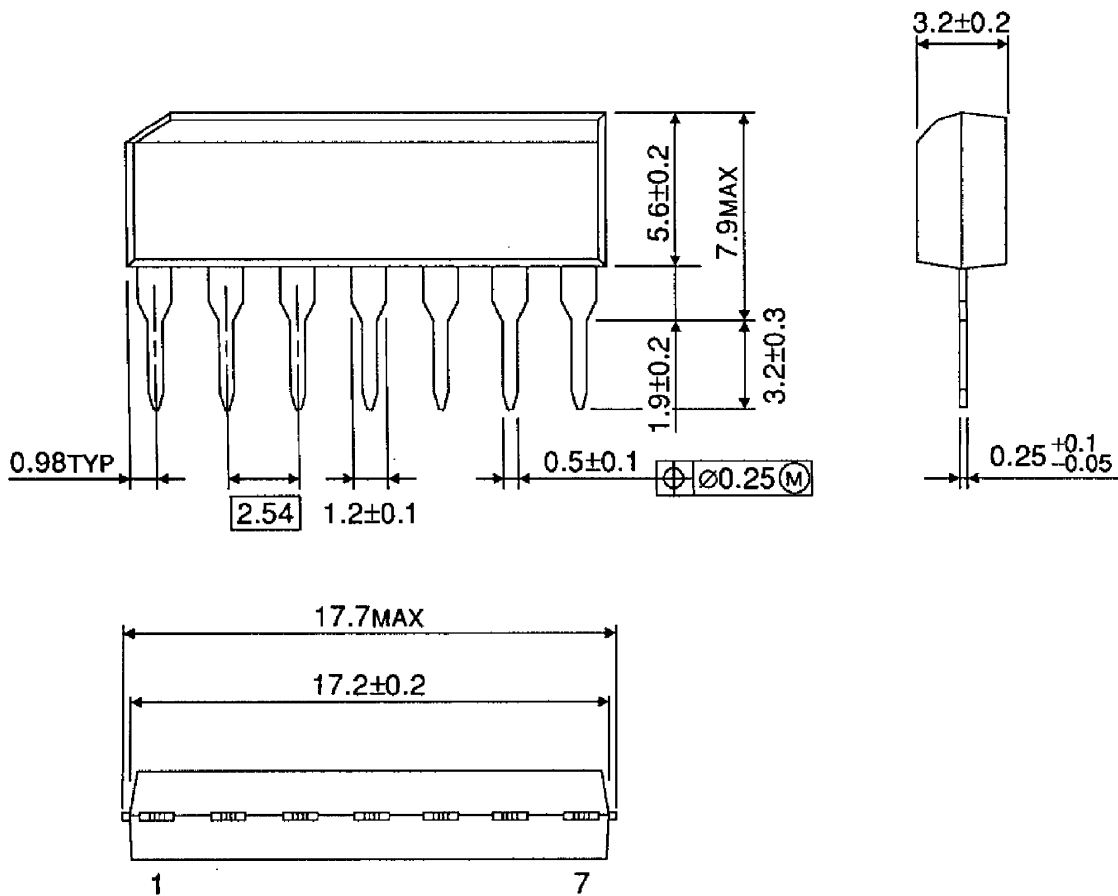

Weight : 0.7g (Typ.)

RESTRICTIONS ON PRODUCT USE

000707EBA

- TOSHIBA is continually working to improve the quality and reliability of its products. Nevertheless, semiconductor devices in general can malfunction or fail due to their inherent electrical sensitivity and vulnerability to physical stress. It is the responsibility of the buyer, when utilizing TOSHIBA products, to comply with the standards of safety in making a safe design for the entire system, and to avoid situations in which a malfunction or failure of such TOSHIBA products could cause loss of human life, bodily injury or damage to property. In developing your designs, please ensure that TOSHIBA products are used within specified operating ranges as set forth in the most recent TOSHIBA products specifications. Also, please keep in mind the precautions and conditions set forth in the "Handling Guide for Semiconductor Devices," or "TOSHIBA Semiconductor Reliability Handbook" etc..
- The TOSHIBA products listed in this document are intended for usage in general electronics applications (computer, personal equipment, office equipment, measuring equipment, industrial robotics, domestic appliances, etc.). These TOSHIBA products are neither intended nor warranted for usage in equipment that requires extraordinarily high quality and/or reliability or a malfunction or failure of which may cause loss of human life or bodily injury ("Unintended Usage"). Unintended Usage include atomic energy control instruments, airplane or spaceship instruments, transportation instruments, traffic signal instruments, combustion control instruments, medical instruments, all types of safety devices, etc.. Unintended Usage of TOSHIBA products listed in this document shall be made at the customer's own risk.
- The products described in this document are subject to the foreign exchange and foreign trade laws.
- The information contained herein is presented only as a guide for the applications of our products. No responsibility is assumed by TOSHIBA CORPORATION for any infringements of intellectual property or other rights of the third parties which may result from its use. No license is granted by implication or otherwise under any intellectual property or other rights of TOSHIBA CORPORATION or others.
- The information contained herein is subject to change without notice.