

isc Thyristors

TIC116M

APPLICATIONS

- 8A continuous on-state current
- 80A surge-current
- Glass passivated
- Max I_{GT} of 20mA

ABSOLUTE MAXIMUM RATINGS($T_a=25^\circ\text{C}$)

SYMBOL	PARAMETER	MIN	UNIT
V_{DRM}	Repetitive peak off-state voltage	600	V
V_{RRM}	Repetitive peak reverse voltage	600	V
$I_{T(AV)}$	On-state current $T_c=80^\circ\text{C}$	5	A
$I_{T(RMS)}$	RMS on-state current $T_c=80^\circ\text{C}$	8	A
I_{TM}	Surge peak on-state current	80	A
P_{GM}	Peak gate power $P_w \leq 300 \mu\text{s}$	5	W
$P_{G(AV)}$	Average gate power	1	W
T_j	Operating Junction temperature	110	$^\circ\text{C}$
T_{stg}	Storage temperature	-40 ~ +125	$^\circ\text{C}$
$R_{th(j-c)}$	Thermal resistance, junction to case	3	$^\circ\text{C/W}$
$R_{th(j-a)}$	Thermal resistance, junction to ambient	62.5	$^\circ\text{C/W}$

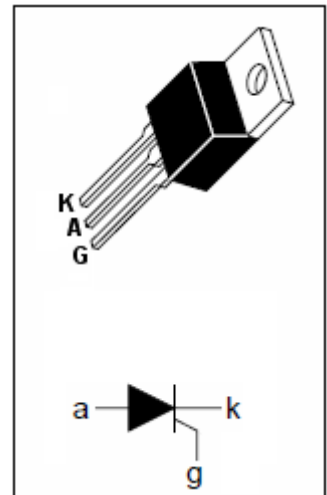
ELECTRICAL CHARACTERISTICS ($T_c=25^\circ\text{C}$ unless otherwise specified)

SYMBOL	PARAMETER	CONDITIONS	MIN	TYP.	MAX	UNIT
I_{RRM}	Repetitive peak reverse current	$V_{RM}=V_{RRM}$, $T_j=110^\circ\text{C}$			2.0	mA
I_{DRM}	Repetitive peak off-state current	$V_{RM}=V_{RRM}$, $T_j=110^\circ\text{C}$			2.0	mA
V_{TM}	On-state voltage	$I_{TM}=8\text{A}$			1.7	V
I_{GT}	Gate-trigger current	$V_{AA}=6\text{V}$; $R_L=100\ \Omega$			20	mA
V_{GT}	Gate-trigger voltage	$V_{AA}=6\text{V}$; $R_L=100\ \Omega$			1.5	V
I_H	Holding current	$V_{AA}=6\text{V}$; $R_{GK}=1\text{k}\ \Omega$, $I_T=100\text{mA}$			40	mA