

Silicon PNP Power Transistors

BD544/A/B/C

DESCRIPTION

- 70 W at 25°C Case Temperature
- Complement to Type BD543/A/B/C
- 8 A Continuous Collector Current

APPLICATIONS

- Designed for high power audio amplifier applications.

ABSOLUTE MAXIMUM RATINGS(T_a=25)

SYMBOL	PARAMETER	VALUE	UNIT	
V _{CBO}	Collector-Base Voltage	BD544	-40	V
		BD544A	-60	
		BD544B	-80	
		BD544C	-100	
V _{CEO}	Collector-Emitter Voltage	BD544	-40	V
		BD544A	-60	
		BD544B	-80	
		BD544C	-100	
V _{EBO}	Emitter-Base Voltage	-5	V	
I _C	Collector Current-Continuous	-8	A	
I _{CM}	Collector Current-Peak	-10	A	
P _C	Collector Power Dissipation @ T _C =25	70	W	
	Collector Power Dissipation @ T _a =25	2		
T _J	Junction Temperature	150		
T _{stg}	Storage Temperature Range	-65~150		

THERMAL CHARACTERISTICS

SYMBOL	PARAMETER	MAX	UNIT
R _{th j-c}	Thermal Resistance, Junction to Case	4.17	/W
R _{th j-a}	Thermal Resistance, Junction to Ambient	62.5	/W

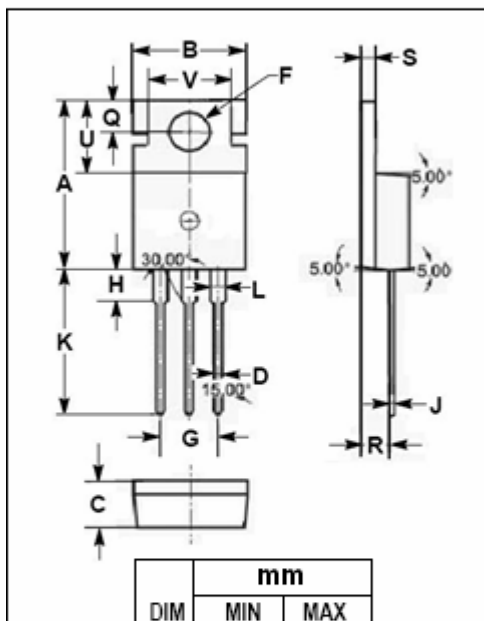
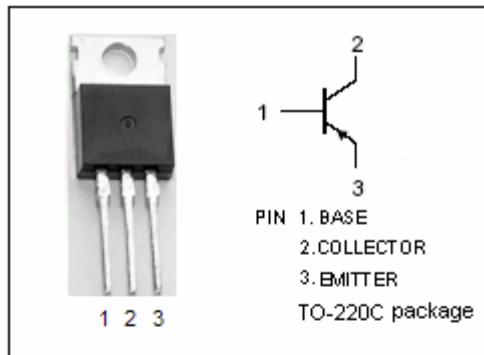

DIM	mm	
	MIN	MAX
A	15.70	15.90
B	9.90	10.10
C	4.20	4.40
D	0.70	0.90
F	3.40	3.60
G	4.98	5.18
H	2.70	2.90
J	0.44	0.46
K	13.20	13.40
L	1.10	1.30
Q	2.70	2.90
R	2.50	2.70
S	1.29	1.31
U	6.45	6.65
V	8.66	8.86

Silicon PNP Power Transistors

BD544/A/B/C

ELECTRICAL CHARACTERISTICS

T_C=25 unless otherwise specified

SYMBOL	PARAMETER		CONDITIONS	MIN	TYP.	MAX	UNIT
V _{(BR)CEO}	Collector-Emitter Breakdown Voltage	BD544	I _C = -30mA ; I _B = 0	-40			V
		BD544A		-60			
		BD544B		-80			
		BD544C		-100			
V _{CE(sat)-1}	Collector-Emitter Saturation Voltage		I _C = -3A; I _B = -0.3A			-0.5	V
V _{CE(sat)-2}	Collector-Emitter Saturation Voltage		I _C = -5A; I _B = -1A			-0.5	V
V _{CE(sat)-3}	Collector-Emitter Saturation Voltage		I _C = -8A; I _B = -1.6A			-1.0	V
V _{BE(on)}	Base-Emitter On Voltage		I _C = -5A; V _{CE} = -4V			-1.4	V
I _{CES}	Collector Cutoff Current	BD544	V _{CE} = -40V; V _{BE} = 0			-0.4	mA
		BD544A	V _{CE} = -60V; V _{BE} = 0			-0.4	
		BD544B	V _{CE} = -80V; V _{BE} = 0			-0.4	
		BD544C	V _{CE} = -100V; V _{BE} = 0			-0.4	
I _{CEO}	Collector Cutoff Current	BD544/A	V _{CE} = -30V; I _B = 0			-0.7	mA
		BD544B/C	V _{CE} = -60V; I _B = 0				
I _{EBO}	Emitter Cutoff Current		V _{EB} = -5V; I _C = 0			-1	mA
h _{FE-1}	DC Current Gain		I _C = -1A ; V _{CE} = -4V	60			
h _{FE-2}	DC Current Gain		I _C = -3A ; V _{CE} = -4V	40			
h _{FE-3}	DC Current Gain		I _C = -5A ; V _{CE} = -4V	15			

Switching Times

t _{on}	Turn-On Time	I _C = -6A; I _{B1} = -I _{B2} = -0.6A; V _{BE(off)} = 4V, R _L = 5		0.4		μs
t _{off}	Turn-Off Time			0.7		μs