

Silicon NPN Power Transistors

MJF15030

DESCRIPTION

- With TO-220F package
- Complement to type MJF15031
- High transition frequency
- DC current gain specified to 4.0 amperes
 $h_{FE} = 40$ (Min) @ $I_C = 3.0$ Adc
 $h_{FE} = 20$ (Min) @ $I_C = 4.0$ Adc

APPLICATIONS

- Designed for general-purpose amplifier and switching applications

PINNING

PIN	DESCRIPTION
1	Base
2	Collector;connected to mounting base
3	Emitter

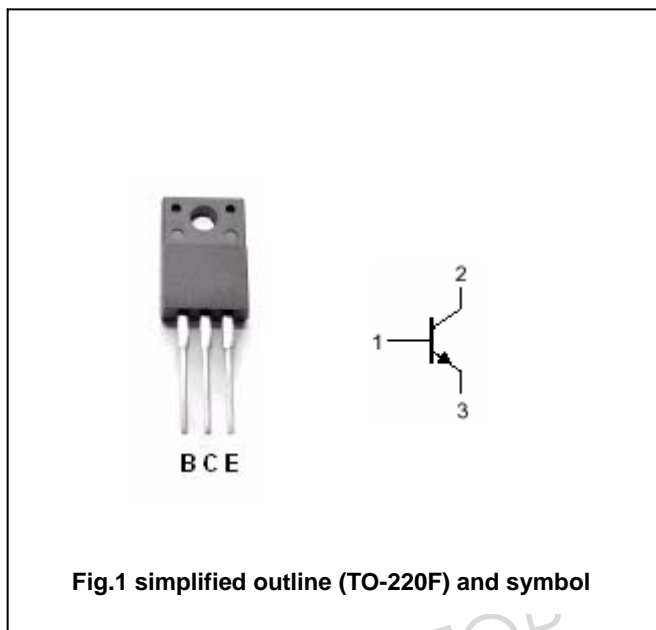

Absolute maximum ratings (Tc=25)

SYMBOL	PARAMETER	CONDITIONS	VALUE	UNIT
V_{CBO}	Collector-base voltage	Open emitter	150	V
V_{CEO}	Collector-emitter voltage	Open base	150	V
V_{EBO}	Emitter-base voltage	Open collector	5	V
I_C	Collector current (DC)		8	A
I_{CM}	Collector current-Peak		16	A
I_B	Base current		2	A
P_D	Total power dissipation	$T_a=25$	2	W
		$T_c=25$	36	
T_j	Junction temperature		150	
T_{stg}	Storage temperature		-65~150	

THERMAL CHARACTERISTICS

SYMBOL	PARAMETER	MAX	UNIT
$R_{th j-C}$	Thermal resistance ; junction to case	3.5	/W
$R_{th j-A}$	Thermal resistance , junction to ambient	62.5	/W

Silicon NPN Power Transistors

MJF15030

CHARACTERISTICS

T_j=25 unless otherwise specified

SYMBOL	PARAMETER	CONDITIONS	MIN	TYP.	MAX	UNIT
V _{CEQ(SUS)}	Collector-emitter sustaining voltage	I _C =10mA; I _B =0	150			V
V _{CEsat}	Collector-emitter saturation voltage	I _C =1A; I _B =0.1A			0.5	V
V _{BE}	Base-emitter on voltage	I _C =1A; V _{CE} =2V			1.0	V
I _{CBO}	Collector cut-off current	V _{CB} =150V; I _E =0			10	μA
I _{CEO}	Collector cut-off current	V _{CE} =150V; I _B =0			10	μA
I _{EBO}	Emitter cut-off current	V _{EB} =5V; I _C =0			10	μA
h _{FE-1}	DC current gain	I _C =0.1A; V _{CE} =2V	40			
h _{FE-2}	DC current gain	I _C =2A; V _{CE} =2V	40			
h _{FE-3}	DC current gain	I _C =3A; V _{CE} =2V	40			
h _{FE-4}	DC current gain	I _C =4A; V _{CE} =2V	20			
f _T	Transition frequency	I _C =0.5A; V _{CE} =10V; f=10MHz	30			MHz

Silicon NPN Power Transistors

MJF15030

PACKAGE OUTLINE

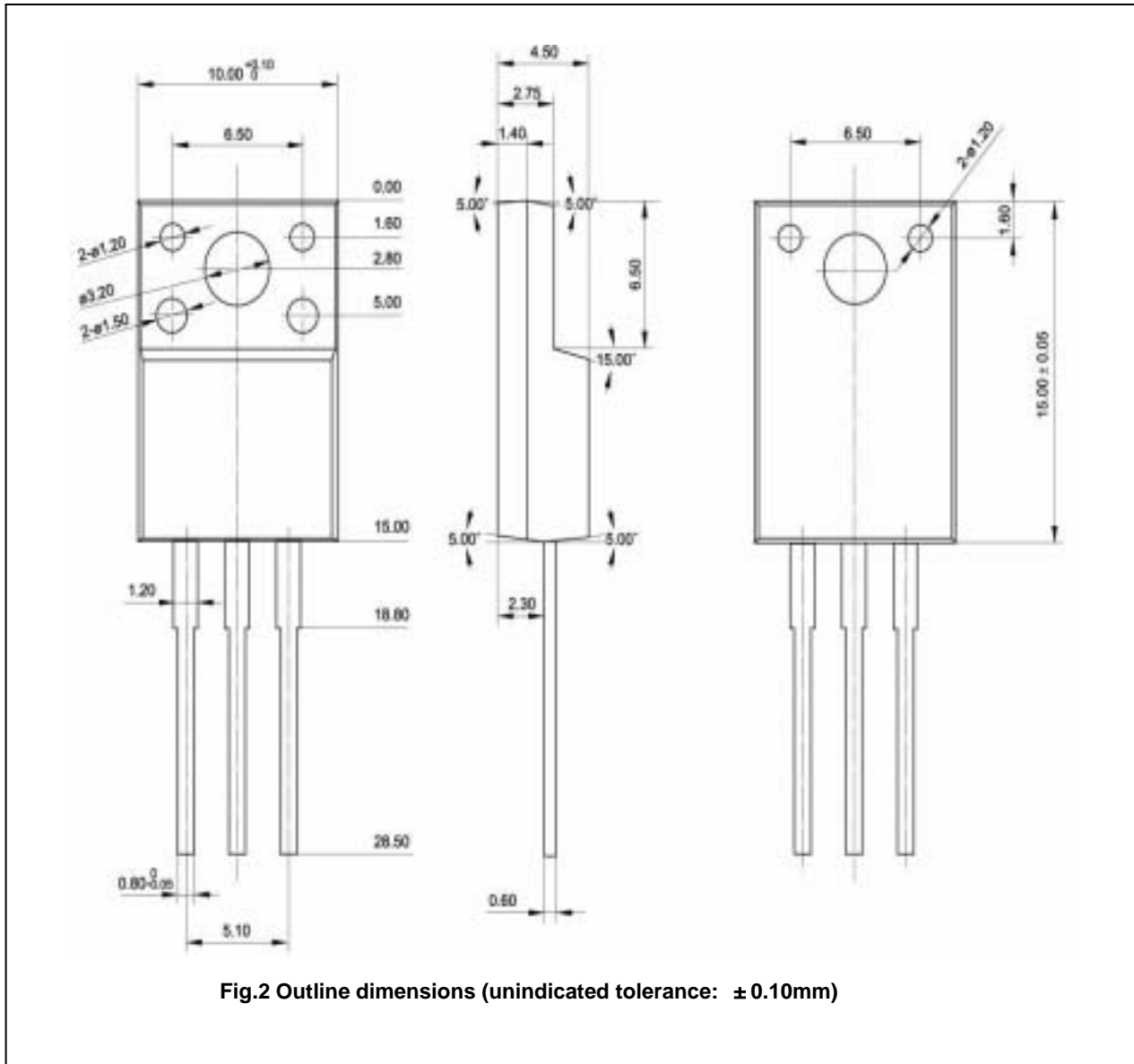

Fig.2 Outline dimensions (unindicated tolerance: ± 0.10mm)

Silicon NPN Power Transistors

MJF15030

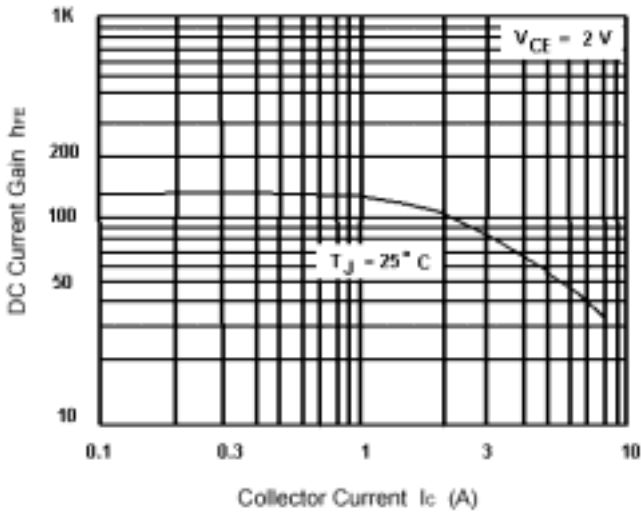

Fig.3 DC current Gain

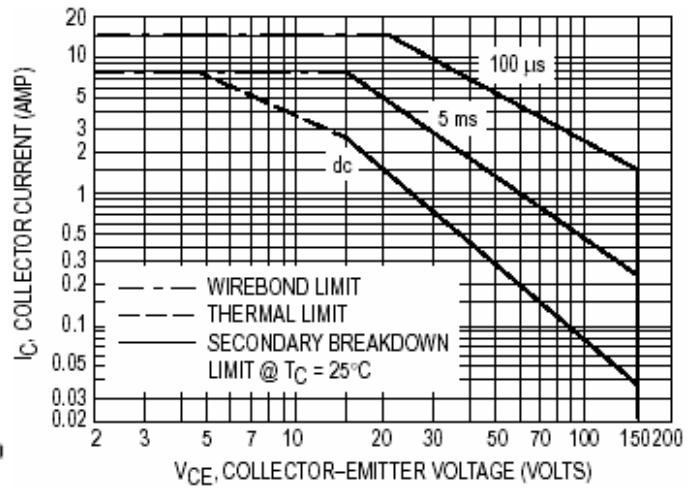

Fig.4 Safe Operating Area

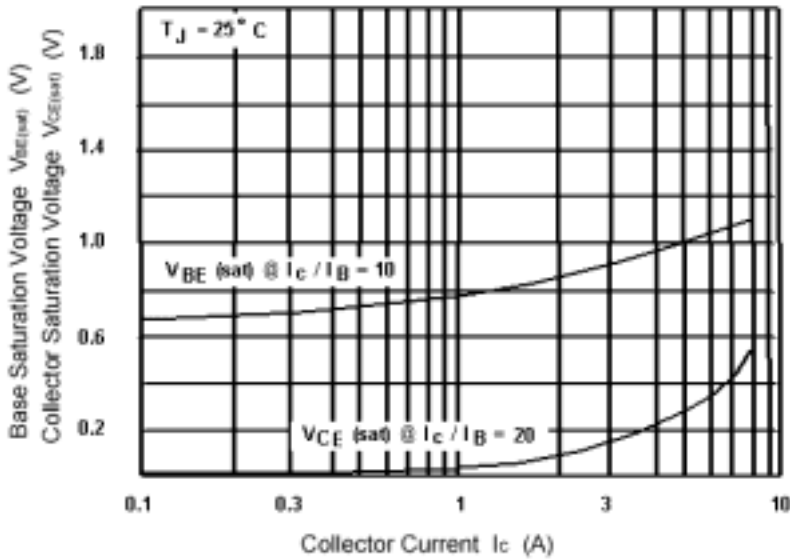

Fig.5 Base-Emitter Saturation Voltage
Collector-Emitter Saturation Voltage