

Silicon NPN Power Transistors

2SC1985 2SC1986

DESCRIPTION

- With TO-220 package
- Complement to type 2SA770/771
- Low collector saturation voltage

APPLICATIONS

- For general and industrial purpose applications

PINNING

PIN	DESCRIPTION
1	Base
2	Collector;connected to mounting base
3	Emitter

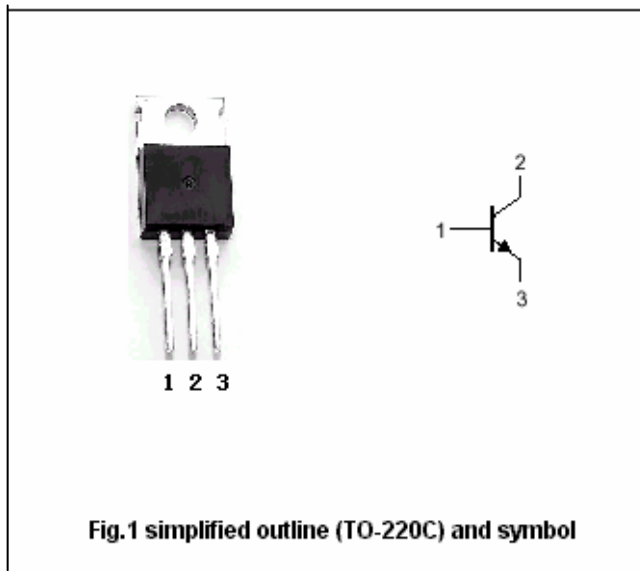

Absolute maximum ratings(Ta=25 )

SYMBOL	PARAMETER	CONDITIONS	VALUE	UNIT
V <sub>CBO</sub>	Collector-base voltage	2SC1985	80	V
		2SC1986	100	
V <sub>CEO</sub>	Collector-emitter voltage	2SC1985	60	V
		2SC1986	80	
V <sub>EBO</sub>	Emitter-base voltage	Open collector	6	V
I <sub>C</sub>	Collector current		6	A
I <sub>B</sub>	Base current		3	A
P <sub>C</sub>	Collector power dissipation	T <sub>C</sub> =25	40	W
T <sub>j</sub>	Junction temperature		150	
T <sub>stg</sub>	Storage temperature		-55~150	

## Silicon NPN Power Transistors

## 2SC1985 2SC1986

## CHARACTERISTICS

T<sub>j</sub>=25 unless otherwise specified

SYMBOL	PARAMETER		CONDITIONS	MIN	TYP.	MAX	UNIT
V <sub>(BR)CEO</sub>	Collector-emitter breakdown voltage	2SC1985	I <sub>C</sub> =25mA, I <sub>B</sub> =0	60			V
		2SC1986		80			
V <sub>CEsat</sub>	Collector-emitter saturation voltage		I <sub>C</sub> =3A; I <sub>B</sub> =0.3A			1.0	V
I <sub>CBO</sub>	Collector cut-off current	2SC1985	V <sub>CB</sub> =80V; I <sub>E</sub> =0			1.0	mA
		2SC1986	V <sub>CB</sub> =100V; I <sub>E</sub> =0				
I <sub>EBO</sub>	Emitter cut-off current		V <sub>EB</sub> =6V; I <sub>C</sub> =0			1.0	mA
h <sub>FE</sub>	DC current gain		I <sub>C</sub> =1A; V <sub>CE</sub> =4V	40			
f <sub>T</sub>	Transition frequency		I <sub>C</sub> =0.5A; V <sub>CE</sub> =12V		10		MHz
Switching times							
t <sub>r</sub>	Rise time		I <sub>C</sub> =3A; V <sub>CC</sub> =9V I <sub>B1</sub> =-I <sub>B2</sub> =0.3A; R <sub>L</sub> =3		1.1		μs
t <sub>stg</sub>	Storage time				1.8		μs
t <sub>f</sub>	Fall time				0.55		μs

Silicon NPN Power Transistors

2SC1985 2SC1986

PACKAGE OUTLINE

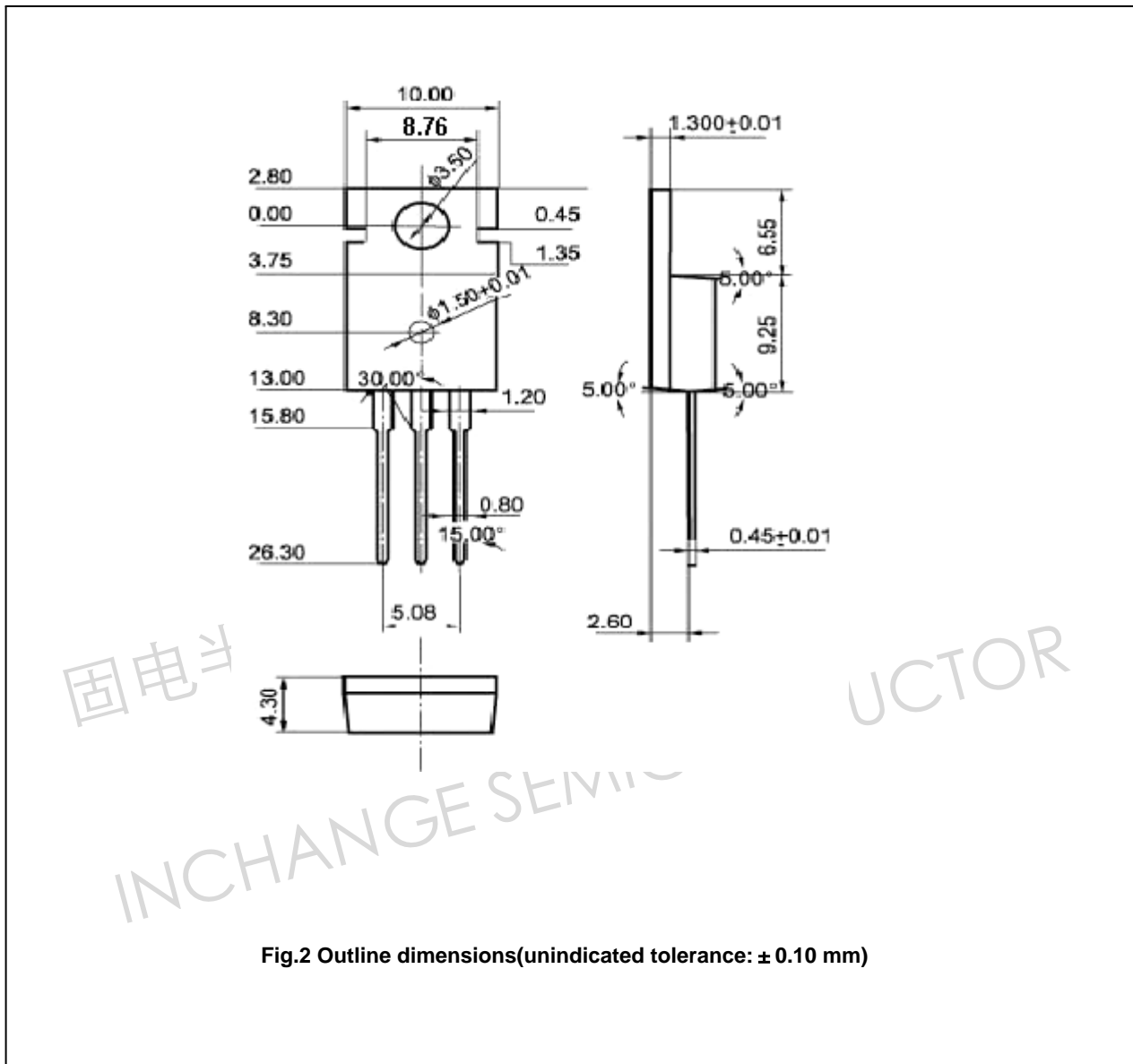

Fig.2 Outline dimensions(unindicated tolerance: ± 0.10 mm)