

Silicon NPN Power Transistors

BU921

DESCRIPTION

- With TO-3 package
- High current;high voltage
- DARLINGTON

APPLICATIONS

- Designed for automotive ignition applications and inverter circuits for motor control.

PINNING(see fig.2)

PIN	DESCRIPTION
1	Base
2	Emitter
3	Collector

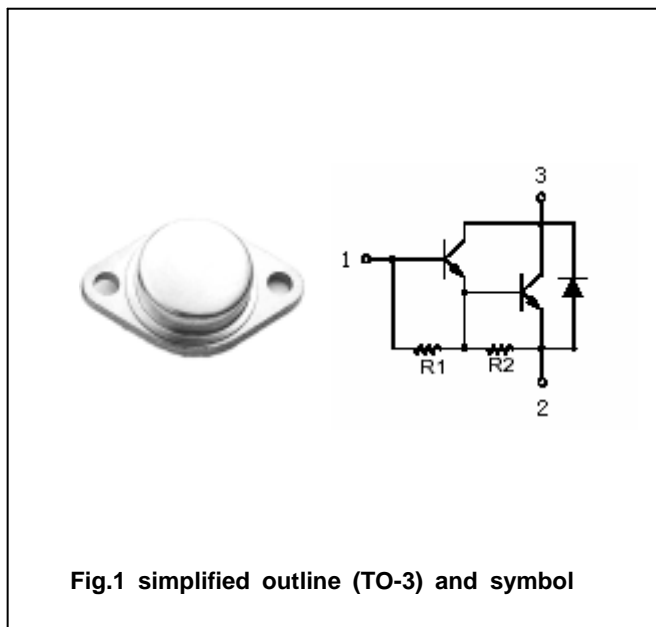

Fig.1 simplified outline (TO-3) and symbol

Absolute maximum ratings (Tc=25)

SYMBOL	PARAMETER	CONDITIONS	VALUE	UNIT
V_{CBO}	Collector-base voltage	Open emitter	450	V
V_{CEO}	Collector-emitter voltage	Open base	400	V
V_{EBO}	Emitter-base voltage	Open collector	5	V
I_C	Collector current		10	A
I_{CM}	Collector current-peak		15	A
I_B	Base current		5	A
P_T	Total power dissipation	$T_C=25$	120	W
T_j	Junction temperature		175	
T_{stg}	Storage temperature		-65~175	

THERMAL CHARACTERISTICS

SYMBOL	PARAMETER	MAX	UNIT
$R_{th j-c}$	Thermal resistance junction to case	1.25	/W

Silicon NPN Power Transistors

BU921

CHARACTERISTICS

T_j=25 unless otherwise specified

SYMBOL	PARAMETER	CONDITIONS	MIN	TYP.	MAX	UNIT
V _{CE0(SUS)}	Collector-emitter sustaining voltage	I _C =0.1A; I _B =0	400			V
V _{CEsat-1}	Collector-emitter saturation voltage	I _C =5A; I _B =50mA			1.8	V
V _{CEsat-2}	Collector-emitter saturation voltage	I _C =7 A; I _B =140mA			1.8	V
V _{BEsat-1}	Base-emitter saturation voltage	I _C =5A; I _B =50mA			2.2	V
V _{BEsat-2}	Base-emitter saturation voltage	I _C =7 A; I _B =140mA			2.5	V
I _{CES}	Collector cut-off current	V _{CE} =450V; V _{BE} =0 T _C =150			0.25 0.50	mA
I _{CEO}	Collector cut-off current	V _{CE} =400V; I _B =0			0.25	mA
I _{EBO}	Emitter cut-off current	V _{EB} =5V; I _C =0			50	mA
h _{FE}	DC current gain	I _C =2A; V _{EB} =2V	500			
V _F	Diode forward voltage	I _F =7A			2.5	V

PACKAGE OUTLINE

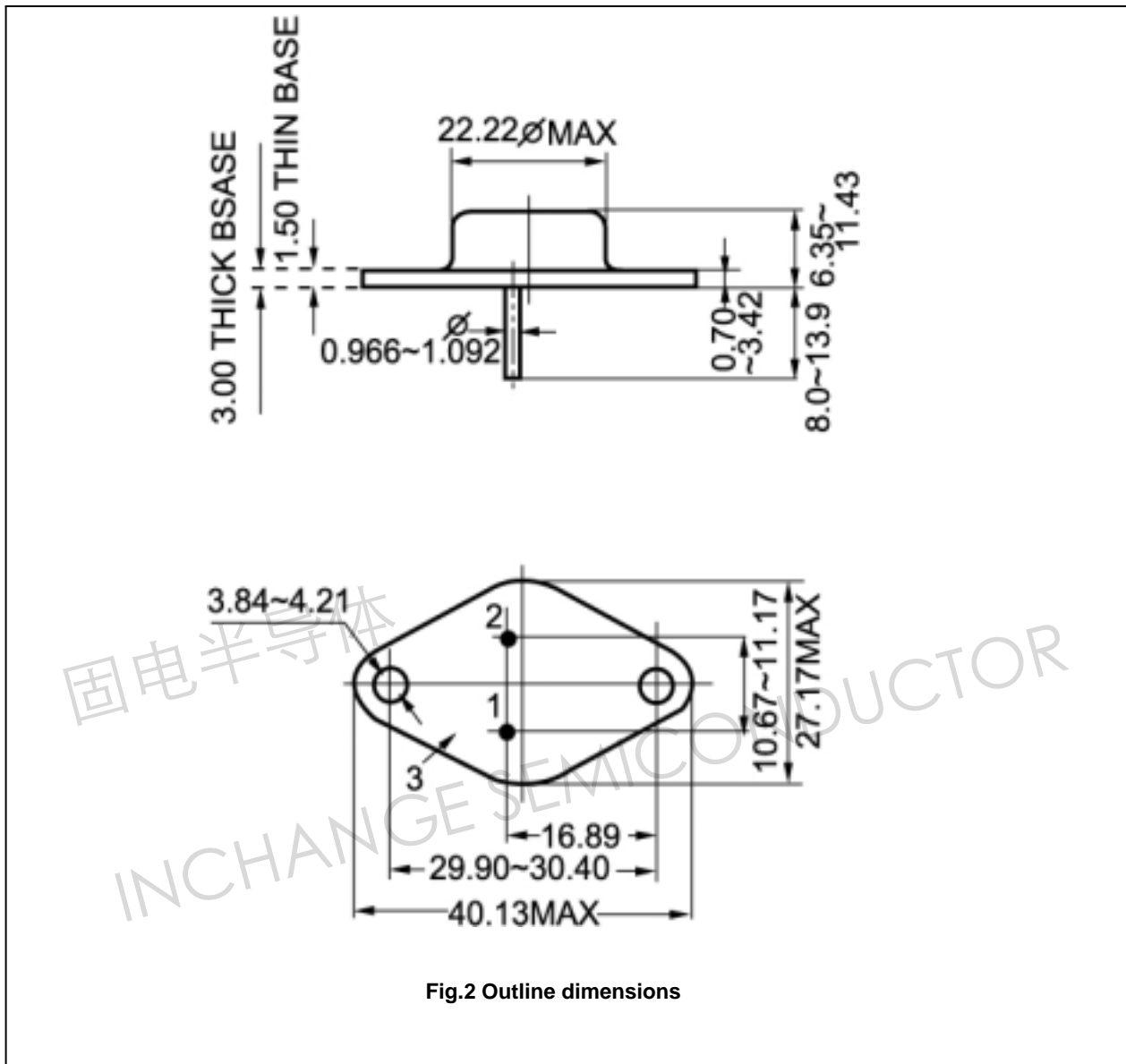

Fig.2 Outline dimensions