

Silicon NPN Power Transistors

2SD2539

DESCRIPTION

- With TO-3P(H)IS package
- High voltage ;high speed
- Low saturation voltage
- Bult-in damper diode

APPLICATIONS

- Horizontal deflection output for color TV

PINNING

PIN	DESCRIPTION
1	Base
2	Collector
3	Emitter

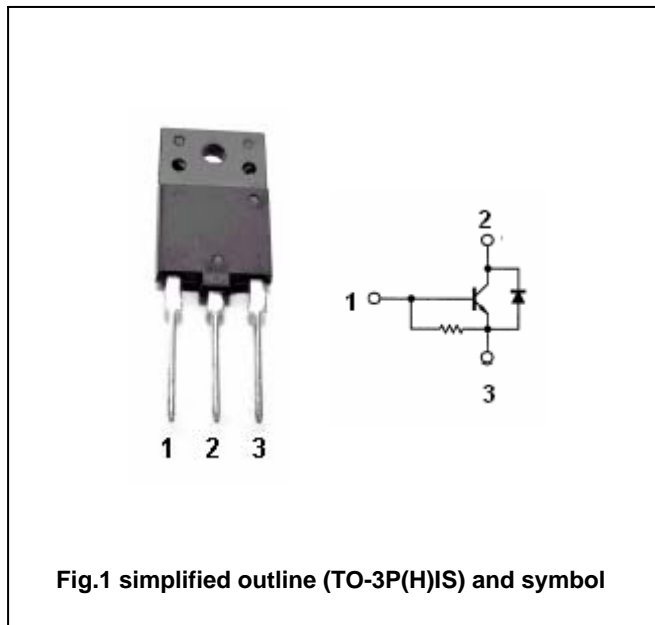

Fig.1 simplified outline (TO-3P(H)IS) and symbol

Absolute maximum ratings(Ta=25)

SYMBOL	PARAMETER	CONDITIONS	VALUE	UNIT
V_{CBO}	Collector-base voltage	Open emitter	1500	V
V_{CEO}	Collector-emitter voltage	Open base	600	V
V_{EBO}	Emitter-base voltage	Open collector	5	V
I_C	Collector current		7	A
I_{CM}	Collector current-peak		14	A
I_B	Base current		3.5	A
P_C	Total power dissipation	$T_C=25$	50	W
T_j	Junction temperature		150	
T_{stg}	Storage temperature		-55~150	

Silicon NPN Power Transistors

2SD2539

CHARACTERISTICS

T_j=25 unless otherwise specified

SYMBOL	PARAMETER	CONDITIONS	MIN	TYP.	MAX	UNIT
V _{(BR)EBO}	Emitter-base breakdown voltage	I _C =400mA ; I _B =0	5			V
V _{CEsat}	Collector-emitter saturation voltage	I _C =5A; I _B =1.0A			5	V
V _{BEsat}	Base-emitter saturation voltage	I _C =5A; I _B =1.0A		1.0	1.3	V
I _{CBO}	Collector cut-off current	V _{CB} =1500V; I _E =0			1	mA
I _{EBO}	Emitter cut-off current	V _{EB} =5V; I _C =0	66		200	mA
h _{FE-1}	DC current gain	I _C =1A ; V _{CE} =5V	8		28	
h _{FE-2}	DC current gain	I _C =5A ; V _{CE} =5V	5		9	
V _F	Diode forward voltage	I _F =5A		1.6	2.0	V
C _{ob}	Collector output capacitance	I _E =0 ; V _{CB} =10V, f=1MHz		115		pF
f _T	Transition frequency	I _C =0.1A ; V _{CE} =10V		2		MHz

Switching times :

t _s	Storage time	I _{CP} =5A; I _{B1} =1.0A f _H =15.75kHz		6	9	μs
t _f	Fall time			0.3	0.6	μs

Silicon NPN Power Transistors

2SD2539

PACKAGE OUTLINE

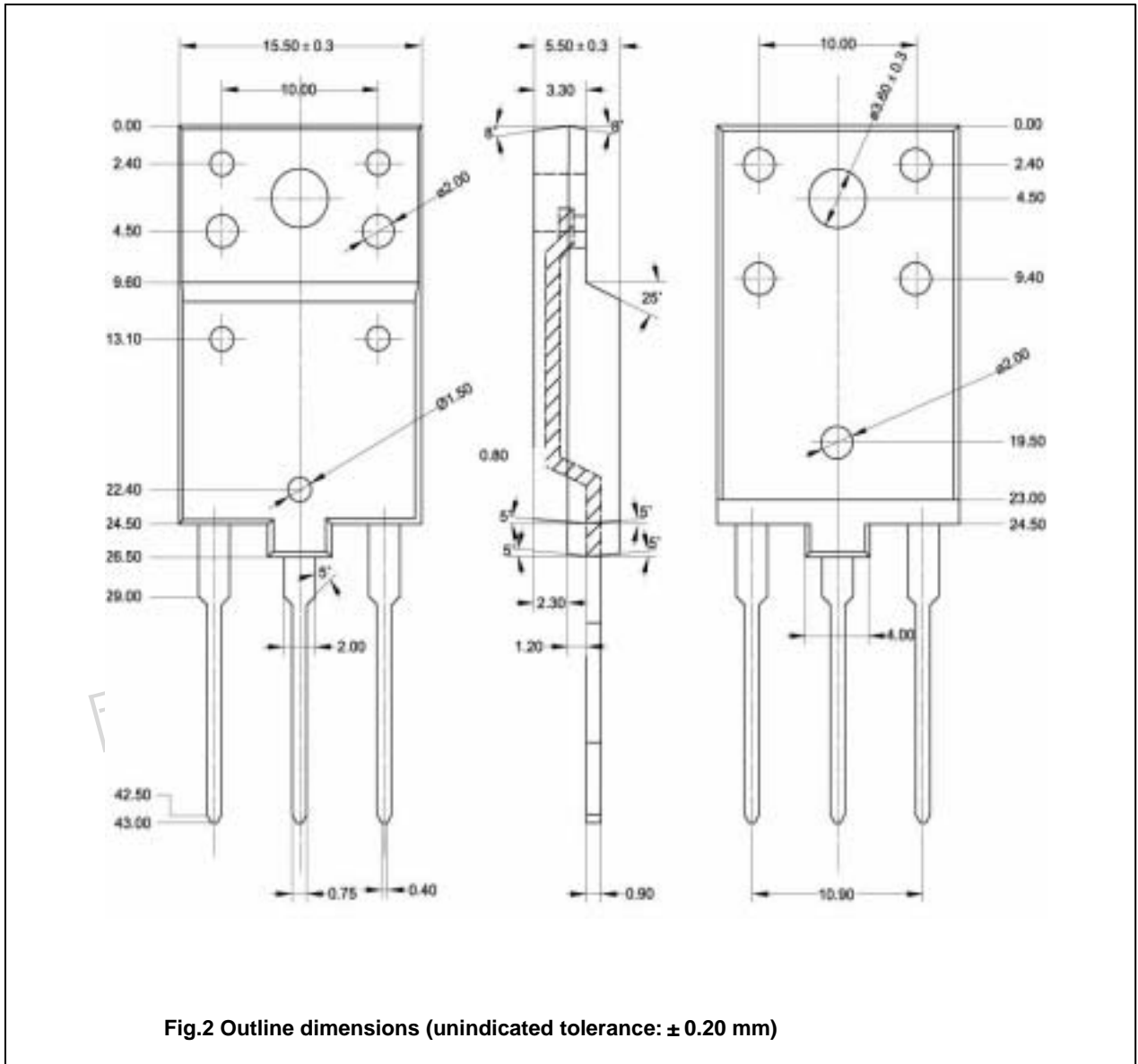

Silicon NPN Power Transistors

2SD2539

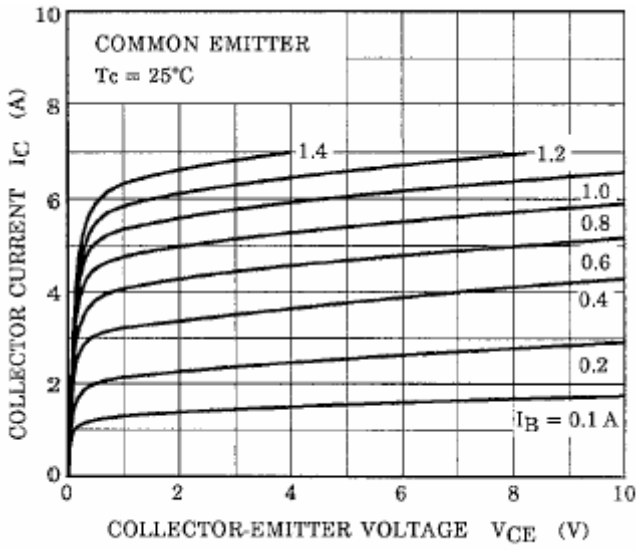

Fig.3 Static Characteristic

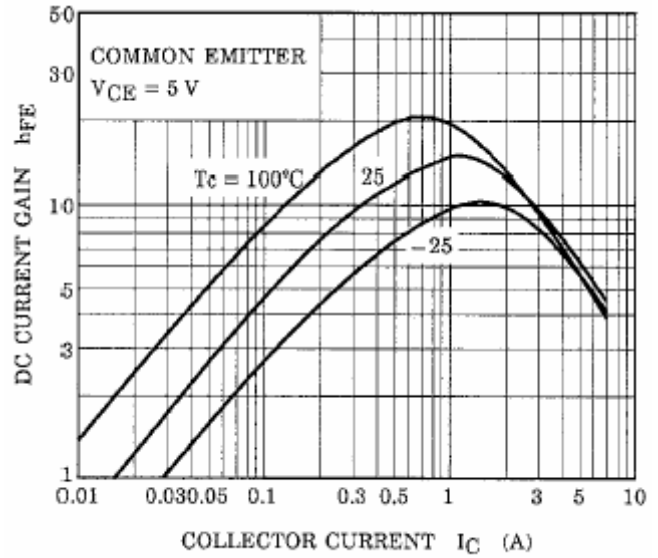

Fig.4 DC current Gain

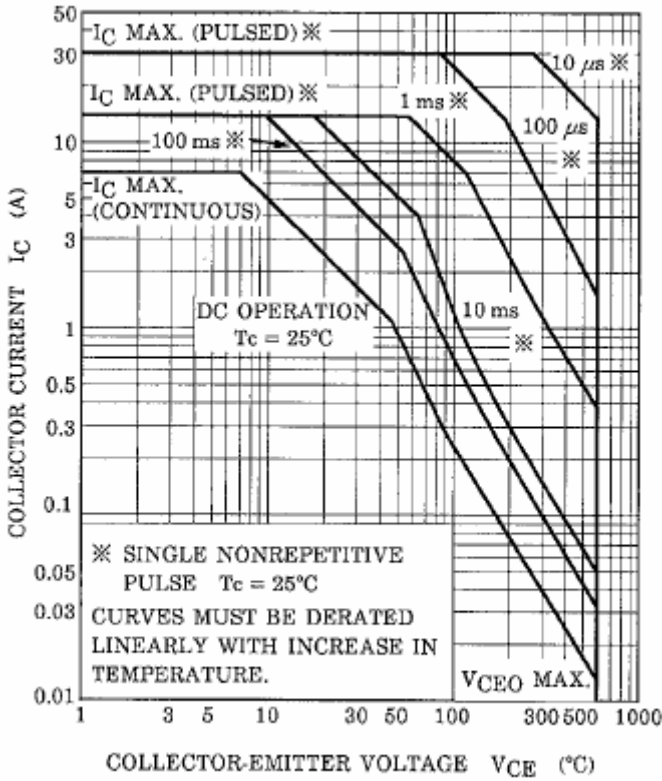

Fig.5 Safe Operating Area