

Silicon PNP Darlington Power Transistors

TIP105/106/107

DESCRIPTION

- With TO-220C package
- DARLINGTON
- High DC current gain
- Low collector saturation voltage
- Complement to type TIP100/101/102

APPLICATIONS

- For industrial use

PINNING

PIN	DESCRIPTION
1	Base
2	Collector;connected to mounting base
3	Emitter

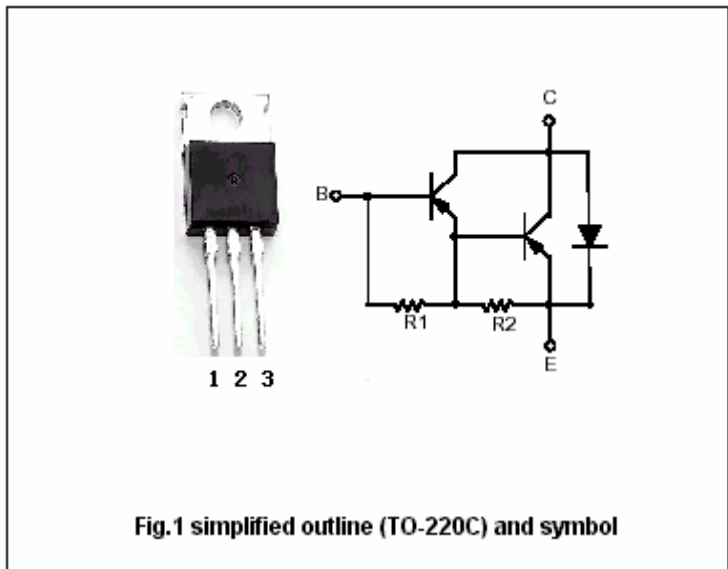

Fig.1 simplified outline (TO-220C) and symbol

Absolute maximum ratings(Tc=25)

SYMBOL	PARAMETER	CONDITIONS	VALUE	UNIT
V _{CBO}	Collector-base voltage	TIP105	-60	V
		TIP106	-80	
		TIP107	-100	
V _{CEO}	Collector-emitter voltage	TIP105	-60	V
		TIP106	-80	
		TIP107	-100	
V _{EBO}	Emitter-base voltage	Open collector	-5	V
I _C	Collector current-DC		-8	A
I _{CM}	Collector current-peak		-15	A
I _B	Base current-DC		-1	A
P _C	Collector power dissipation	T _c =25	80	W
		T _a =25	2	
T _j	Junction temperature		150	
T _{stg}	Storage temperature		-65~150	

Silicon PNP Darlington Power Transistors

TIP105/106/107

CHARACTERISTICS

T_j=25 unless otherwise specified

SYMBOL	PARAMETER	CONDITIONS	MIN	TYP.	MAX	UNIT	
V _{CEQ(SUS)}	Collector-emitter sustaining voltage	TIP105	-60			V	
		TIP106	-80				
		TIP107	-100				
V _{CEsat-1}	Collector-emitter saturation voltage	I _C =-3A, I _B =-6mA			-2.0	V	
V _{CEsat-2}	Collector-emitter saturation voltage	I _C =-8A, I _B =-80mA			-2.5	V	
V _{BE}	Base-emitter on voltage	I _C =-8A; V _{CE} =-4V			-2.8	V	
I _{CBO}	Collector cut-off current	TIP105	V _{CB} =-60V, I _E =0			-50	μA
		TIP106	V _{CB} =-80V, I _E =0				
		TIP107	V _{CB} =-100V, I _E =0				
I _{CEO}	Collector cut-off current	TIP105	V _{CE} =-30V, I _B =0			-50	μA
		TIP106	V _{CE} =-40V, I _B =0				
		TIP107	V _{CE} =-50V, I _B =0				
I _{EBO}	Emitter cut-off current	V _{EB} =-5V; I _C =0			-2	mA	
h _{FE-1}	DC current gain	I _C =-3A; V _{CE} =-4V	1000		20000		
h _{FE-2}	DC current gain	I _C =-8A; V _{CE} =-4V	200				
C _{ob}	Output capacitance	I _E =0; V _{CB} =-10V, f=0.1MHz			300	pF	

