

TBA970 Television Video Amplifier

General Description

The TBA970 is a monolithic video amplifier for television receivers. The circuitry includes a video preamplifier, DC contrast control utilizing a linear potentiometer which can be ganged to the chroma gain control, beam current limiting via contrast. Beam current limiting could be obtained with either positive or negative control voltage. Black level control is achieved by a clamped feedback circuit combined with the brightness control. Emitter follower output could be used to directly drive the video output stage. A separate NPN transistor (Q40) is provided on the chip.

Features

- DC contrast control
- DC brightness control
- Black level clamping
- Beam current limiting
- Low impedance output

Connection Diagram

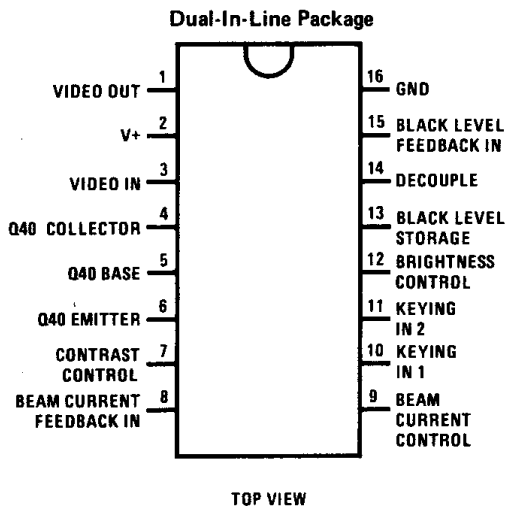

Dual-In-Line Package, Order Number TBA970
See NS Package N16A

Quad-In-Line Package, Order Number TBA970Q
See NS Package N16C

Block Diagram

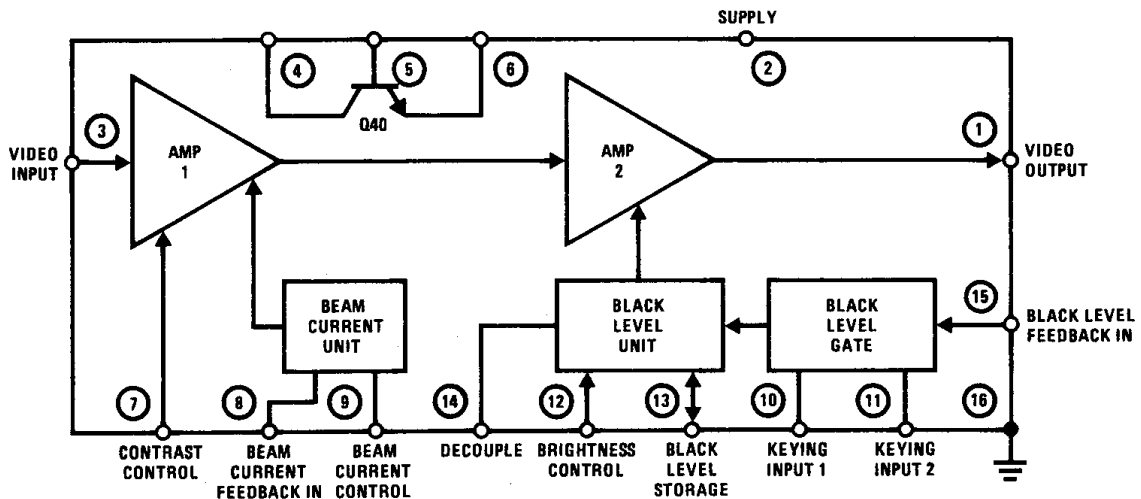

Absolute Maximum Ratings

Supply Voltage	15.5V	V _{CE} S Q40	15.5V
Internal Power Dissipation	750 mW	Operating Temperature Range	-20°C to +45°C
Collector Current Q40	10 mA	Storage Temperature Range	-55°C to +125°C
Power Dissipation Q40	20 mW	Lead Temperature (Soldering, 10 seconds)	260°C
V _{CEO} Q40	13.2V		

Electrical Characteristics $T_A = 25^\circ\text{C}$, $V^+ = 15\text{V}$, See Test Circuit, unless otherwise specified

SYMBOL	PARAMETER	CONDITIONS	MIN	TYP	MAX	UNITS
I ₂	Supply Current	(Note 1)		27	36	mA
V ₃ p-p	Peak-to-Peak Input Voltage	(Note 2)			1.6	V _{p-p}
R ₃	Input Resistance			12		kΩ
	Voltage Gain			2.4		
	3.0 dB Bandwidth			6.0		MHz
	6.0 dB Bandwidth			9.0		MHz
	Linearity of Black-to-White Video Output Signal		0.9			
V ₁₅	Low Black Level Voltage				0.2	V
V ₁₅	High Black Level Voltage		3.0			V
	Contrast Control Range	$1.5\text{V} \leq V_7 \leq 4.5\text{V}$	36			dB
R ₁₂	Input Resistance for Brightness Control			200		kΩ
ΔV ₁₅	Change of Black Level	(Note 3)			20	mV
V ₈ , V ₉	DC Voltage for Beam Current Limiting Inputs	(Note 4)		2.0		V
	Separate Transistor Q40 Gain	$I_C = I_4 = 1.0\text{ mA}$	40			

Note 1: No input signal and at minimum brightness.

Note 2: With negative-going synchronizing pulse.

Note 3: With constant brightness setting, due to change of picture content, contrast control setting and change in ambient temperature ($\Delta T_A = 20^\circ\text{C}$); black level clamping with $t_C = 1\ \mu\text{s}$, $I_{I0} \geq 0.25\text{ mA}$, $V_{11} \leq 0.3\text{V}$.

Note 4: Beam current limiting occurs at $V_8 \geq V_9$.

Test Circuit

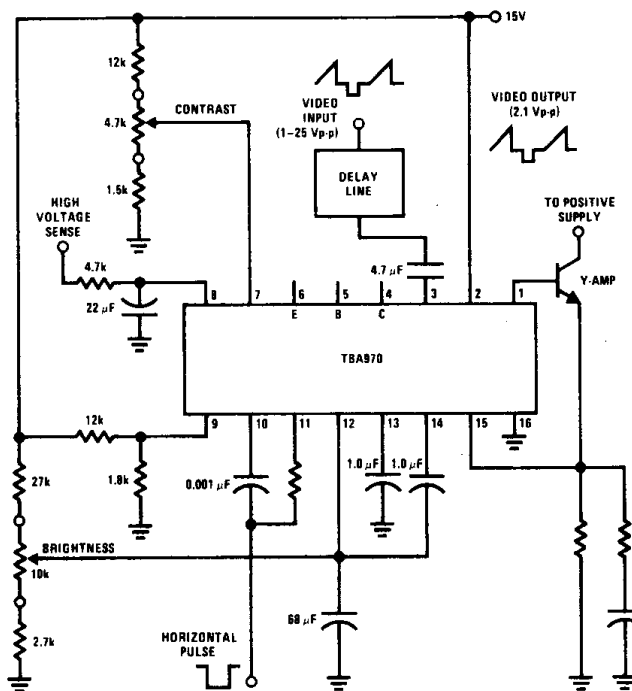

Equivalent Circuit

TBA970

11

