

Silicon NPN Power Transistor

BU2725DF

DESCRIPTION

- High Switching Speed
- High Voltage
- Built-in Ddamper Ddiode

APPLICATIONS

- Designed for use in horizontal deflection circuits of color TV receivers.

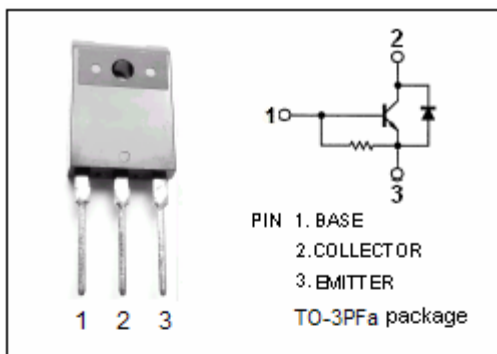

ABSOLUTE MAXIMUM RATINGS( $T_a=25$  )

SYMBOL	PARAMETER	VALUE	UNIT
$V_{CES}$	Collector- Emitter Voltage( $V_{BE}=0$ )	1200	V
$V_{EBO}$	Emitter-Base Voltage	7.5	V
$I_C$	Collector Current- Continuous	12	A
$I_{CM}$	Collector Current-Peak	30	A
$I_B$	Base Current- Continuous	12	A
$I_{BM}$	Base Current-Peak	20	A
$P_C$	Collector Power Dissipation @ $T_C=25$	45	W
$T_J$	Junction Temperature	150	
$T_{stg}$	Storage Temperature Range	-65~150	

SYMBOL	PARAMETER	MAX	UNIT
$R_{th j-c}$	Thermal Resistance, Junction to Case	2.8	/W

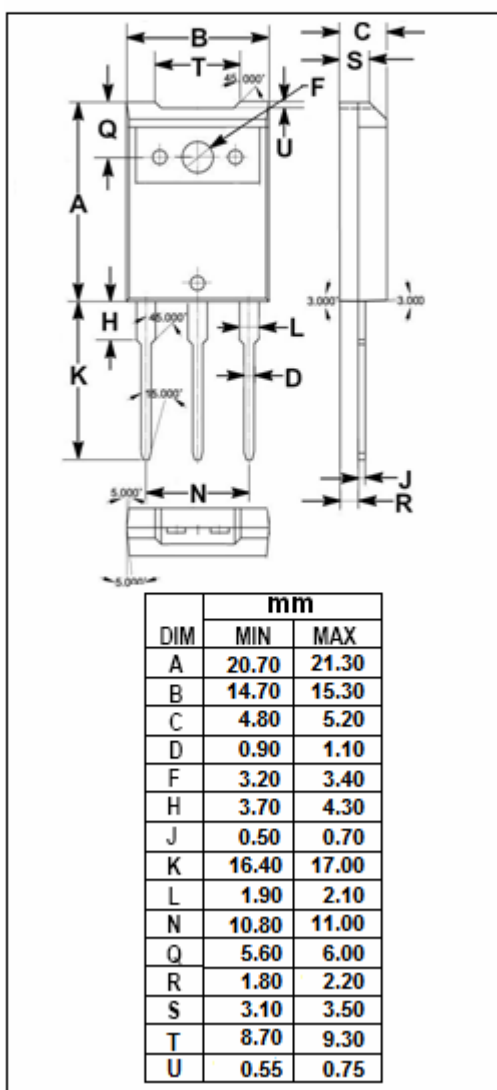

## Silicon NPN Power Transistor

## BU2725DF

## ELECTRICAL CHARACTERISTICS

 $T_C=25$  unless otherwise specified

SYMBOL	PARAMETER	CONDITIONS	MIN	TYP.	MAX	UNIT
$V_{(BR)EBO}$	Emitter-Base Breakdown Voltage	$I_E=600\text{mA}; I_C=0$	7.5			V
$V_{CE(sat)}$	Collector-Emitter Saturation Voltage	$I_C=7\text{A}; I_B=1.75\text{A}$			1.0	V
$V_{BE(sat)}$	Base-Emitter Saturation Voltage	$I_C=7\text{A}; I_B=1.75\text{A}$			0.95	V
$I_{CES}$	Collector Cutoff Current	$V_{CE}=1200\text{V}; V_{BE}=0$ $V_{CE}=1200\text{V}; V_{BE}=0; T_C=125$			1.0 2.0	mA
$I_{EBO}$	Emitter Cutoff Current	$V_{EB}=7.5\text{V}; I_C=0$		110		mA
$h_{FE-1}$	DC Current Gain	$I_C=1\text{A}; V_{CE}=5\text{V}$		19		
$h_{FE-2}$	DC Current Gain	$I_C=7\text{A}; V_{CE}=1\text{V}$	3.8		7.8	
$V_{ECF}$	C-E Diode Forward Voltage	$I_F=7\text{A}$			2.2	V