

LINEAR INTEGRATED CIRCUIT

TV SIGNAL PROCESSING CIRCUIT

The TBA 311 is a monolithic integrated circuit in a 16-lead dual in-line or quad in-line plastic package. It is intended for use as signal processing circuit for black and white and colour television sets.

The circuit is designed for receivers equipped with tubes or transistors in the deflection and video output stages, and with PNP or NPN transistors in the tuner and NPN in the IF amplifier.

Only signals with the negative modulation can be handled by the circuit. The circuit is protected against short circuit between video output and GND. The TBA 311 includes:

- VIDEO PREAMPLIFIER with EMITTER FOLLOWER OUTPUT
- GATED AGC for VIDEO IF AMPLIFIER and TUNER
- NOISE INVERTER CIRCUIT for GATING AGC and SYNC. PULSE SEPARATOR
- HORIZONTAL SYNC. PULSE SEPARATOR
- VERTICAL SYNC. PULSE SEPARATOR
- BLANKING FACILITY for the VIDEO AMPLIFIER

ABSOLUTE MAXIMUM RATINGS

V_s	Supply voltage	16 V
P_{tot}	Power dissipation at $T_{amb} \leq 70^\circ\text{C}$	500 mW
T_{stg}	Storage temperature	-55 to 125 °C
T_{op}	Operating temperature	-25 to 70 °C

ORDERING NUMBERS:

TBA 311 A22 (for 16-lead quad in-line plastic package)

TBA 311 A17 (for 16-lead dual in-line plastic package)

TBA 311

MECHANICAL DATA (Dimensions in mm)

Quad in-line plastic package
for TBA 311 A22

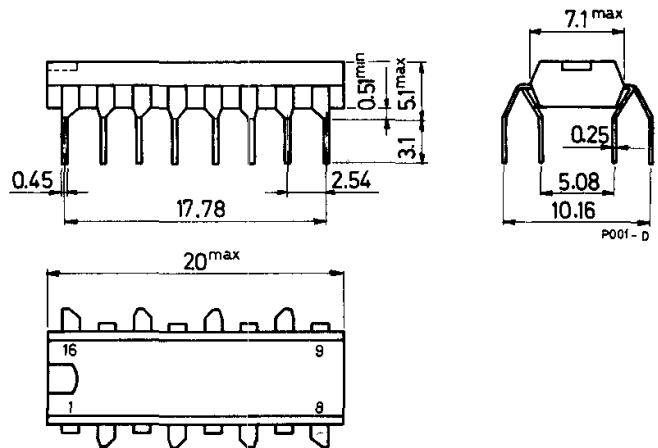

Dual in-line plastic package
for TBA 311 A17

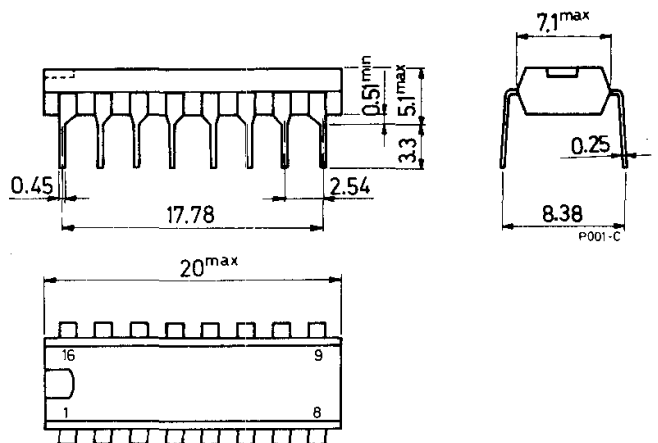

TBA 311

CONNECTION DIAGRAM

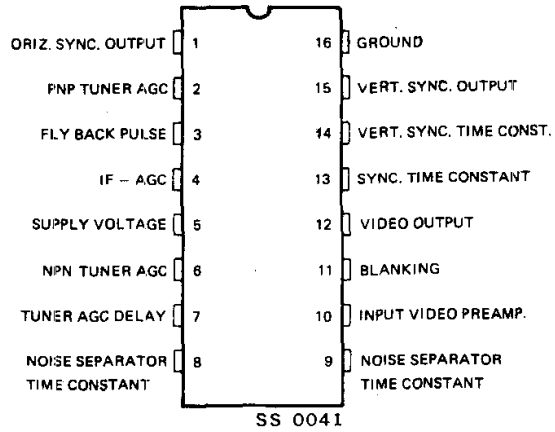

SCHEMATIC DIAGRAM

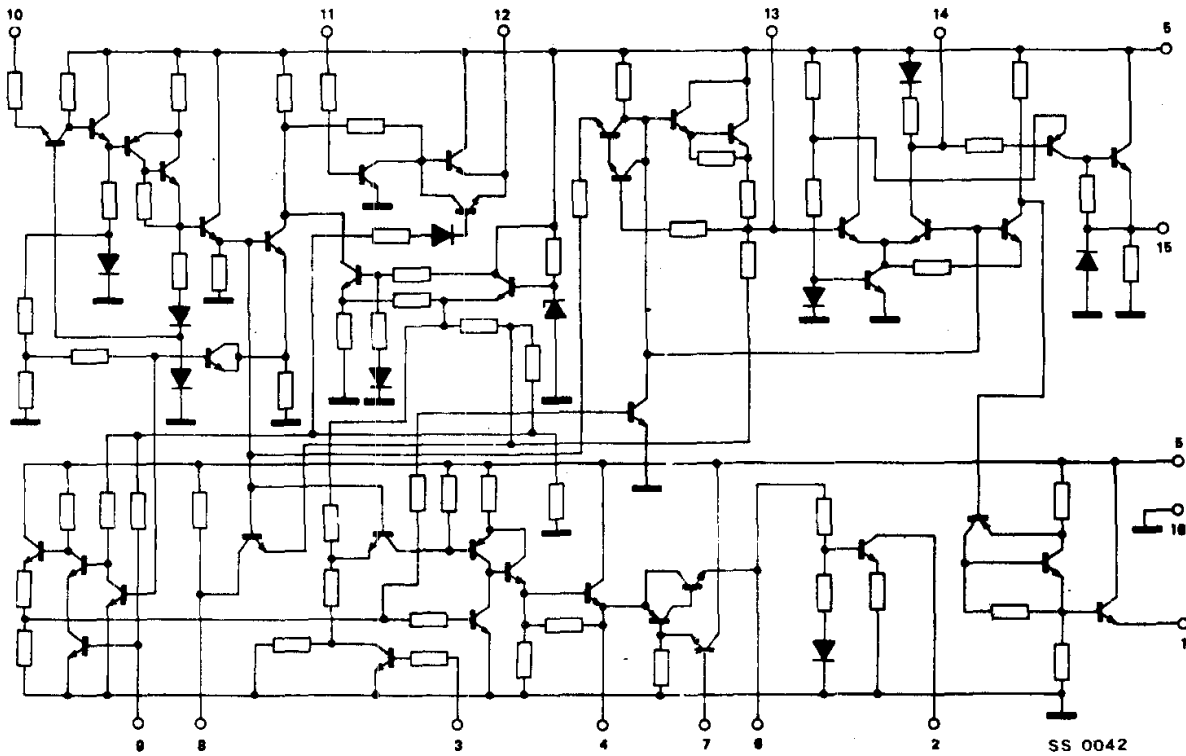

TBA 311

TEST CIRCUIT

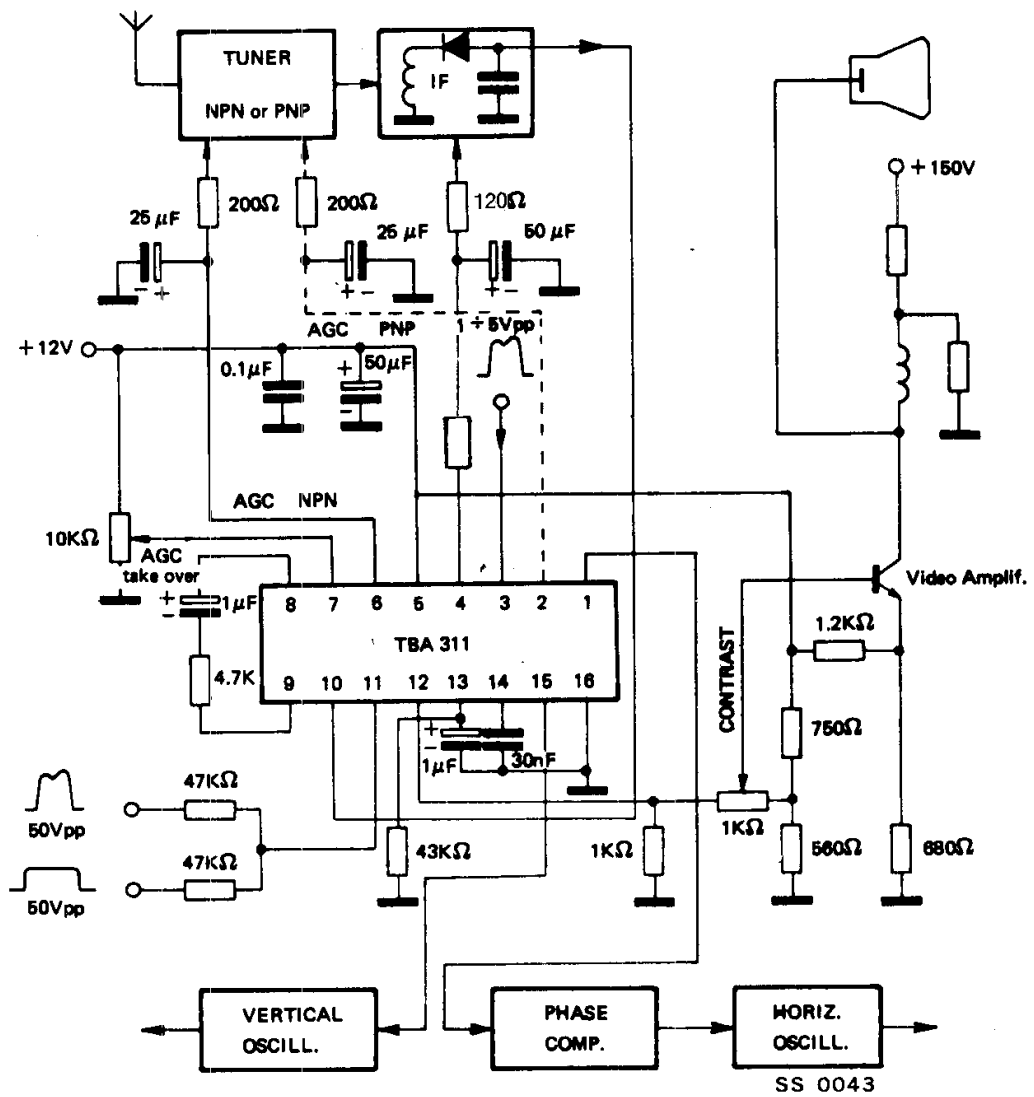

TBA 311

ELECTRICAL CHARACTERISTICS

($T_{amb} = 25\text{ }^{\circ}\text{C}$, $V_s = 12\text{ V}$ unless otherwise specified, see also test circuit)

Parameter	Min.	Typ.	Max.	Unit
I_d Quiescent drain current		14		mA

VIDEO AMPLIFIER

R_i Input resistance (pin 10)		2.7		$k\Omega$
C_i Input capacitance (pin 10)		0.8		pF
B Bandwidth (-3 dB)		5		MHz
G_v Voltage gain		9.5		dB
V_i Peak to peak video input voltage (pin 10)	(1)	2		V
V_o Peak to peak video output voltage (pin 12)	(2)	6		V
V Black level at the output (pin 12)	(3)	5		V
I_o Available video peak output current	(4)	20		mA
$\frac{\Delta V_o}{\Delta T_{amb}}$ Video output voltage temperature drift	(5)	1		mV/ $^{\circ}\text{C}$
$\frac{\Delta V}{\Delta T_{amb}}$ Black level temperature drift		0.2		mV/ $^{\circ}\text{C}$
$\frac{\Delta V}{\Delta V_s}$ Black level drift at the output with supply voltage variation		0.5		V/V

VIDEO BLANKING

V_i Peak to peak input voltage (pin 11)		1	5	V
R_i Input resistance (pin 11)		1		$k\Omega$

AGC CIRCUIT

V Control voltage IF amplifier (pin 4)		0 to 7.5		V
V Control voltage tuner NPN (pin 6)		0 to 6.5		V
PNP (pin 2)		12 to 6		V

TBA 311

ELECTRICAL CHARACTERISTICS (continued)

Parameter	Min.	Typ.	Max.	Unit
$\frac{\Delta V_i}{\Delta V}$ Signal expansion for full control of IF amplifier and tuner		10		%
V Peak to peak keying input pulse (pin 3) (6)	1		5	V
R_i Input resistance (pin 3)		2		k Ω

SYNC. CIRCUITS

V_o Output voltage of horizontal sync. pulse (pin 1)	8.4	10		V
Z_o Horizontal output impedance (pin 1)		100		Ω
V_o Output voltage of vertical sync. pulse (pin 15)	8.4	9.5		V
Z_o Vertical output impedance (pin 15)		2		k Ω

NOTES:

- 1) Negative going video signal (no pre-bias needed for the detector).
- 2) Video signal with negative going sync. pulse.
- 3) Only valid if the video signal is in accordance with the CCIR standard.
- 4) The total load on pin 12 must be such that under nominal conditions $I_o \leq 20$ mA.
- 5) Because the integrated circuit reaches 95% of its final working temperature in 100 seconds, the temperature variations to be considered are those caused by the slower rise in cabinet temperature and by changes in room temperature.
- 6) The TBA 311 may be operated unkeyed but then point 3 must be connected to the positive supply line via a resistor of suitable value (e.g. 10 k Ω). However, the following consequences should be borne in mind:
 - The decoupling capacitors at the IF and tuner control points must be larger to prevent ripple voltages due to the vertical sync pulses. In consequence the AGC will not follow fast signal fluctuations (aircraft flutter).