

TOSHIBA BIPOLAR LINEAR INTEGRATED CIRCUIT SILICON MONOLITHIC

TA7736P, TA7736F

DC MOTOR DRIVER IC

The TA7736P is a 3 phase Bi-directional motor driver IC. It designed for use VCR, tape deck, floppy disk and record player motor drivers.

It contains output power drivers, position sensing circuits, control amplifier and CW/CCW control circuit.

FEATURES

- 3 Phase Bi-Directional Driver and Output Current Up to 1.0A.
- Few External Parts Required.
- Wide Operating Supply Voltage Range
: $V_{CC}(\text{opr})$ (Min.) = 7~20V
- Forward and Reverse Rotation is Controlled Simply by Means of a CW/CCW Control Signal Fed Into 16PIN.
- High Sensitivity of Position Sensing Amplifier.
($V_H = 10\text{mV}_{\text{p-p}}$ (Typ.), Recommend to Use TOSHIBA Ga-As Hall Sensor "THS" Series.)
- Surge Protect Diode Connected for All Input Terminals.
(Position Sensing, Control, CW/CCW Control Inputs.)

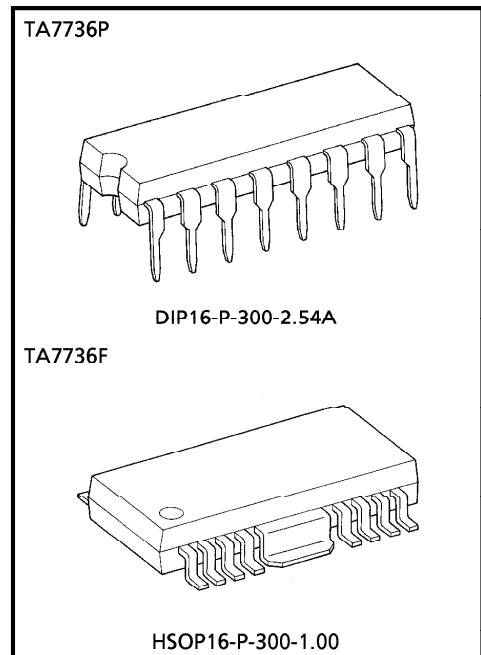

Weight
 DIP16-P-300-2.54A : 1.11g (Typ.)
 HSOP16-P-300-1.00 : 0.50g (Typ.)

961001EBA2

- TOSHIBA is continually working to improve the quality and the reliability of its products. Nevertheless, semiconductor devices in general can malfunction or fail due to their inherent electrical sensitivity and vulnerability to physical stress. It is the responsibility of the buyer, when utilizing TOSHIBA products, to observe standards of safety, and to avoid situations in which a malfunction or failure of a TOSHIBA product could cause loss of human life, bodily injury or damage to property. In developing your designs, please ensure that TOSHIBA products are used within specified operating ranges as set forth in the most recent products specifications. Also, please keep in mind the precautions and conditions set forth in the TOSHIBA Semiconductor Reliability Handbook.
- The products described in this document are subject to foreign exchange and foreign trade control laws.
- The information contained herein is presented only as a guide for the applications of our products. No responsibility is assumed by TOSHIBA CORPORATION for any infringements of intellectual property or other rights of the third parties which may result from its use. No license is granted by implication or otherwise under any intellectual property or other rights of TOSHIBA CORPORATION or others.
- The information contained herein is subject to change without notice.

BLOCK DIAGRAM

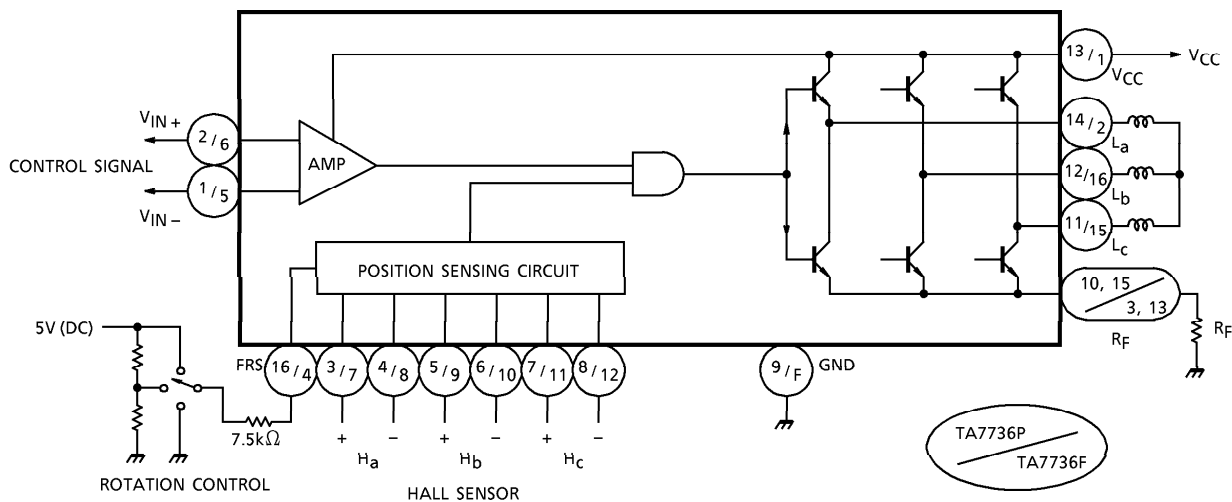

PIN FUNCTION

PIN No.		SYMBOL	FUNCTIONAL DESCRIPTION
P	F		
1	5	V_{IN-}	Control Amp. negative terminal
2	6	V_{IN+}	Control Amp. positive terminal
3	7	H_a+	a-phase Hall Amp. positive input terminal
4	8	H_a-	a-phase Hall Amp. negative input terminal
5	9	H_b+	b-phase Hall Amp. positive input terminal
6	10	H_b-	b-phase Hall Amp. negative input terminal
7	11	H_c+	c-phase Hall Amp. positive input terminal
8	12	H_c-	c-phase Hall Amp. negative input terminal
9	FIN	GND	GND terminal
10	3	R_F	Output current detection terminal
11	15	L_c	c-phase drive output terminal
12	16	L_b	b-phase drive output terminal
13	1	V_{CC}	power supply input terminal
14	2	L_a	a-phase drive output terminal
15	13	R_F	Output current detection terminal
16	4	FRS	Forward rotation / Reverse rotation switch terminal

F : ⑭Pin : No connection

INPUT VS OUTPUT

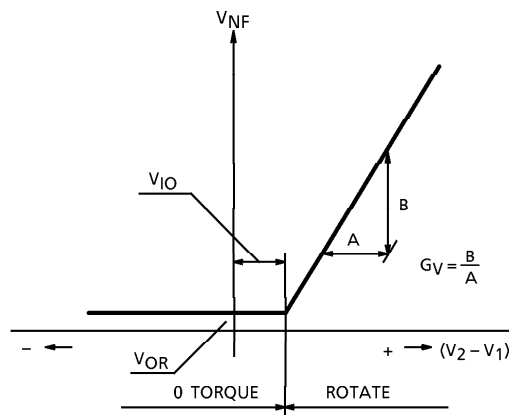

V_{NF} shows voltage drop at R_F .

This is in the case of star connection, when coil current is I_L

$$V_{NF} = R_F \cdot I_L$$

See the following circuit.

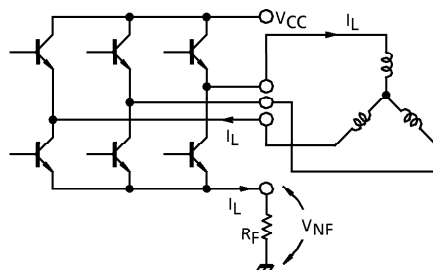

Further, if inputs (pin①, ⑤, pin②, ⑥) are shorted or $V_1 \geq V_2$, torque at the circuit, becomes zero. However, this zero torque state also can be obtained by setting FRS input (pin⑩, ④) to specified voltage or by placing the circuit in open state and this is rather advantageous as current consumption is less.

FUNCTION

FRS (PIN⑩, ④)	POSITION SENSING INPUT			COIL OUTPUT		
	H _a	H _b	H _c	L _a	L _b	L _c
L	1	0	1	H	L	M
	1	0	0	H	M	L
	1	1	0	M	H	L
	0	1	0	L	H	M
	0	1	1	L	M	H
	0	0	1	M	L	H
H	1	0	1	L	H	M
	1	0	0	L	M	H
	1	1	0	M	L	H
	0	1	0	H	L	M
	0	1	1	H	M	L
	0	0	1	M	H	L
M	1	0	1	High Impedance		
	1	0	0			
	1	1	0			
	0	1	0			
	0	1	1			
	0	0	1			

(Note) "1" of Hole element input means that voltage above +10mV is applied to the positive side of each hall element from the negative side and "0" means that voltage above +10mV is applied to the negative side from the positive side. In this case, needless to say, DC potential must be within the specified common mode voltage range of hall element input.

Further, "H", "M" and "L" of output mean $V_{CC} - V_{SAT1} \cong \frac{1}{2} V_{CC}$ and V_{SAT2} , respectively, and "L", "H" and "M" of FRS input mean application of voltage within specified values of V_F , V_R and V_S , respectively.

Further, by applying required voltage for control input (V_{IN+} , V_{IN-}), measure the circuit in operating state.

MAXIMUM RATINGS (Ta = 25°C)

CHARACTERISTIC		SYMBOL	RATING	UNIT
Supply Voltage		V_{CC}	26	V
Output Current		I_O	1.0	A
Power Dissipation	TA7736P	P_D (Note)	1.2	W
	TA7736F		0.9	
Operating Temperature		T_{opr}	-30~75	°C
Storage Temperature		T_{stg}	-55~150	°C

(Note) No heat sink

ELECTRICAL CHARACTERISTICS (Unless otherwise specified, $V_{CC} = 12V$, $T_a = 25^\circ C$)

CHARACTERISTIC		SYMBOL	TEST CIRCUIT	TEST CONDITION	MIN.	TYP.	MAX.	UNIT
Quiescent Current		I_{CC1}	1	FRS = Open	2	4	7	mA
		I_{CC2}		FRS = 5V	2	5	9	
		I_{CC3}		$V_{CC} = 22V$, FRS = GND	2	5	9	
Input Offset Voltage		V_{IO}	1		—	40	—	mV
Residual Output Voltage		V_{OR}	1	$V_1 = V_2 = 7V$	—	0	10	mV
Voltage Gain		G_V	1	$R_{NF} = 2.2\Omega$	—	15.0	—	
Saturation Voltage	Upper	V_{SAT1}	2	$I_L = 400mA$	—	1.0	1.5	V
	Lower	V_{SAT2}		$I_L = 400mA$	—	0.4	1.0	
Cut-off Current	Upper	I_{OC1}	—	$V = 20V$	—	—	20	μA
	Lower	I_{OC2}		$V = 20V$	—	—	20	
Position Sensing Input Sensitivity		V_H	1		—	10	—	mV
Maximum Position Sensing Input Voltage		$V_H \text{ MAX.}$	1		—	—	400	mV
Input Operating Voltage	Position	CMR_H	1		2.0	—	$V_{CC} - 2.5$	V
	Control	CMR_C	1		2.0	—	$V_{CC} - 2.5$	V
Rotation Control Input Voltage	CW	V_F	1		—	0	0.4	V
	STOP	V_S	1		2.2	2.7	3.2	V
	CCW	V_R	1		4.8	5.0	5.8	V

TEST CIRCUIT 1

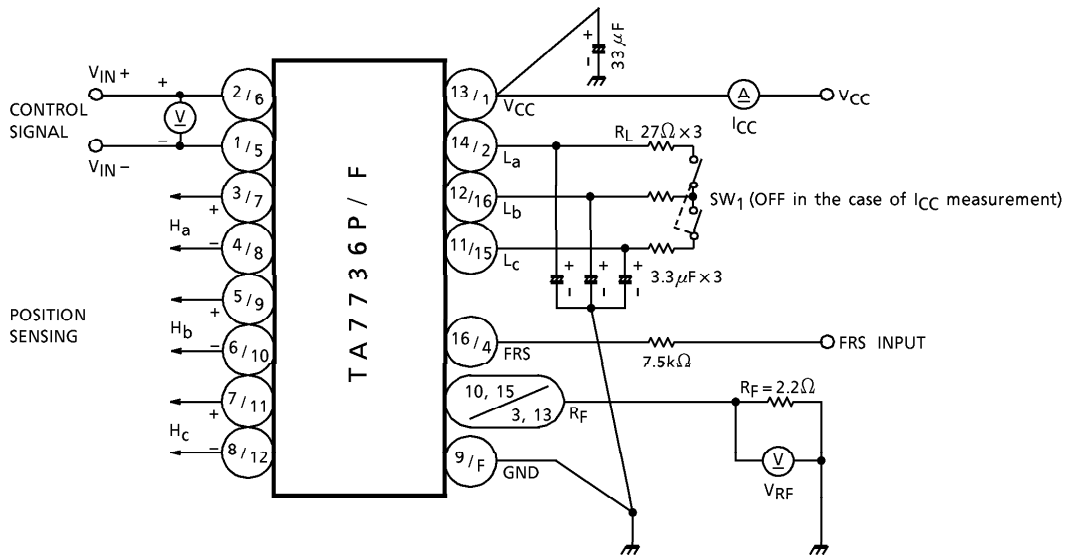

TEST CIRCUIT 2

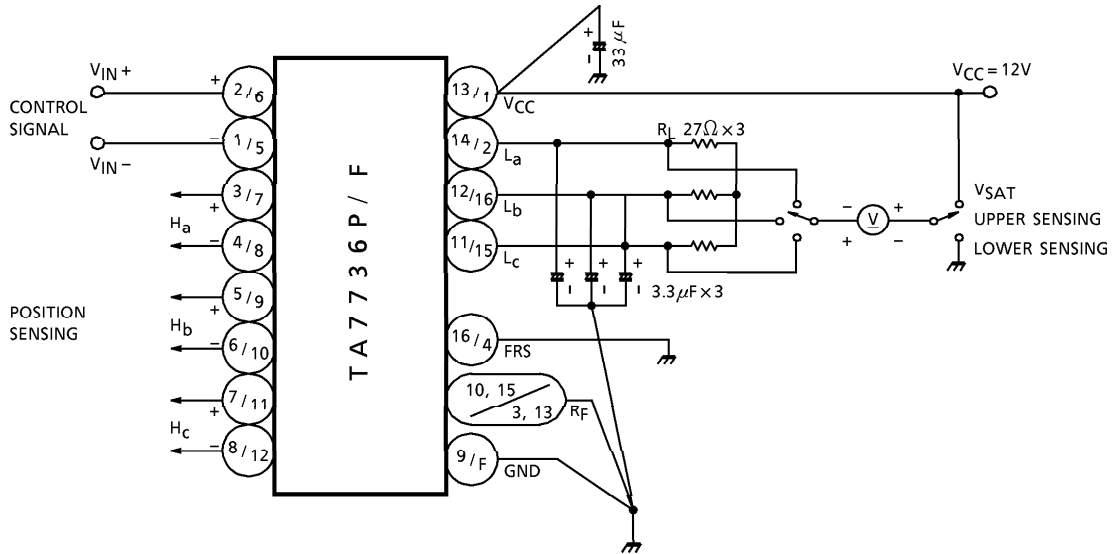

TA7736P

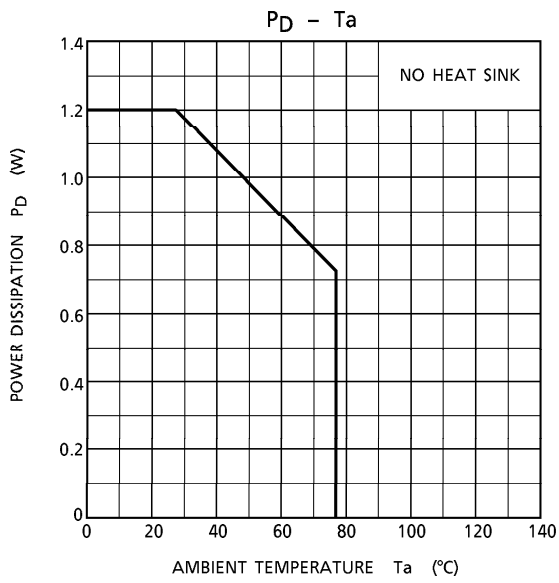

TA7736F

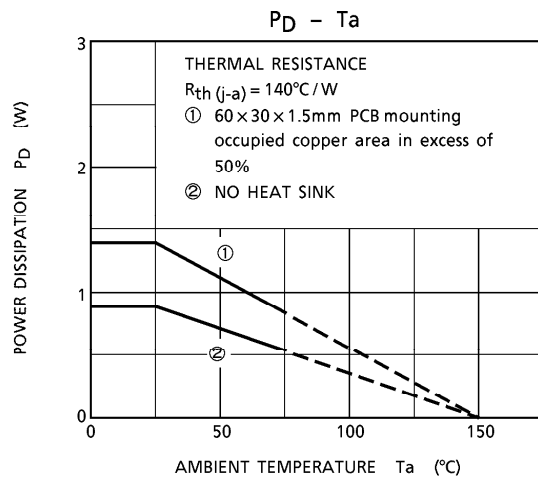

APPLICATION CIRCUIT 1
(Basic application circuit)

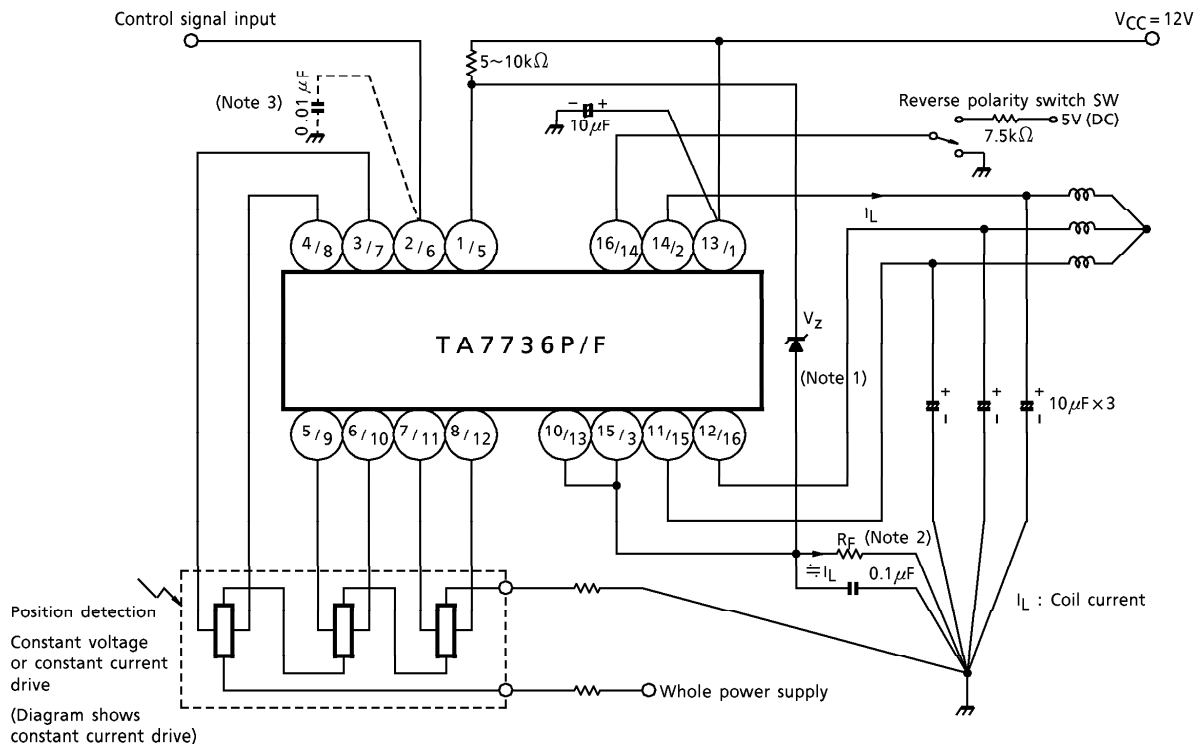

- (Note 1) Set the Zener diode V_z to the control signal input DC level.
(V_z setting recommended at 2.5 to 9.0V; 5.0V depending on temperature characteristics. With load control input pins (1) and (5), the DC electric potential becomes $V_z + R_f \cdot I_L$.)
- (Note 2) R_f is set depending on the coil impedance, F/V transfer voltage (control input) and required starting torque. Set between 0.3 and 5 Ω .
- (Note 3) Connect when dive to control input occurs.

APPLICATION CIRCUIT 2

(TC9142AP + TA7736P $3\frac{1}{2}$ PLL FDD)

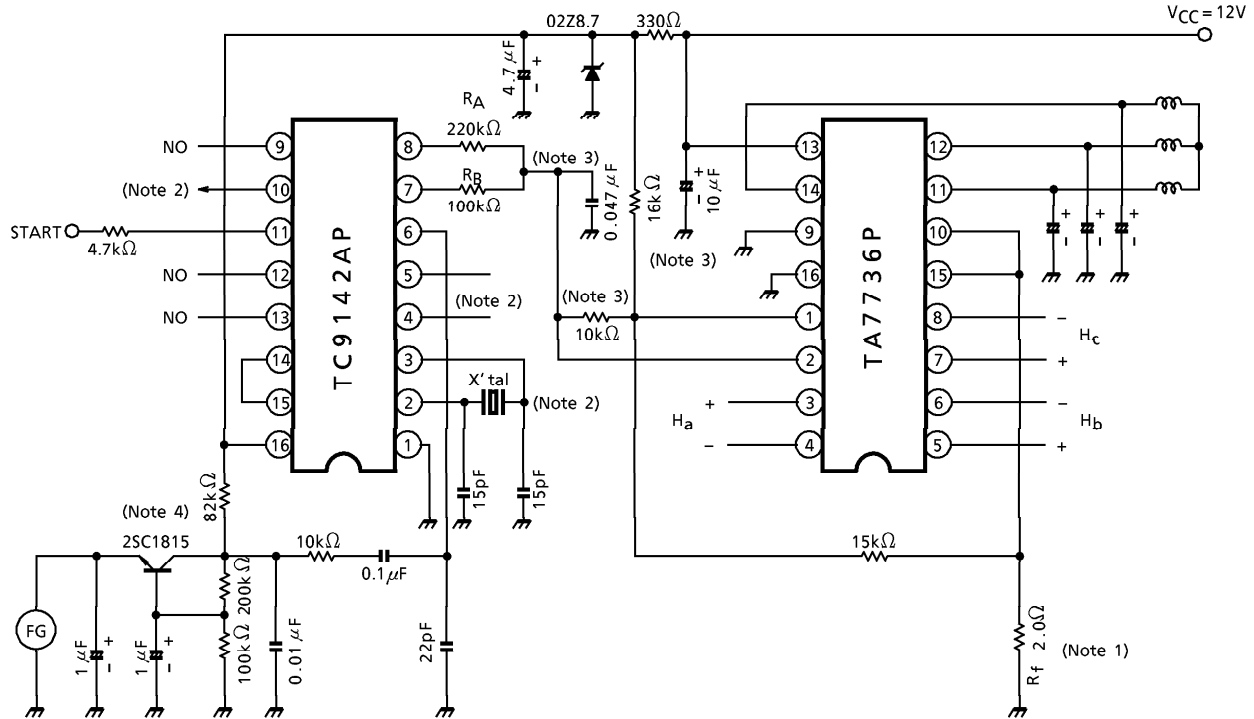

(Note 1) R_f is a feed back Resistor that's voltage drop is equal to Input Voltage ($V_2 - V_1$) in this application with feed back by Zener Diode.

(Note 2) Required X'tal frequency is calculated by following
 $f_x = (no \cdot a / 60) \cdot 128 \cdot 20 N = 42.6 no \cdot a \cdot N$ (at PIN④ "High" state)
 $f_x = (no \cdot a / 60) \cdot 128 \cdot 27 N = 57.6 no \cdot a \cdot N$ (at PIN⑤ "Low" state)

PIN④	PIN⑤	N
H	H	32
L	H	128
H	L	4

Where

- no : Required Rotation Speed (rpm)
- a : Number of FG pulse (pulse / rotation)
- N : Count Down Ratio (4.32 or 128)

(Note 3) Recommended value of R_A and R_B is 50kΩ to 300kΩ
 The combination ratio of F/V and P/V output is designed by changing these value. For example, if you want more F/V conversion gain compare to P/V's one for fast system initial start up. Use a higher value of R_B compare to R_A .

(Note 4) TC9142P's FG Amplifier gain is 30dB (Typ.) and required input signal is over 30mV_{rms}.
 If the FG doesn't output over this value.
 Required a Front Amplifier.

APPLICATION CIRCUIT 3
(TC9203AF + TA7736F 3.5 PLL HDD)

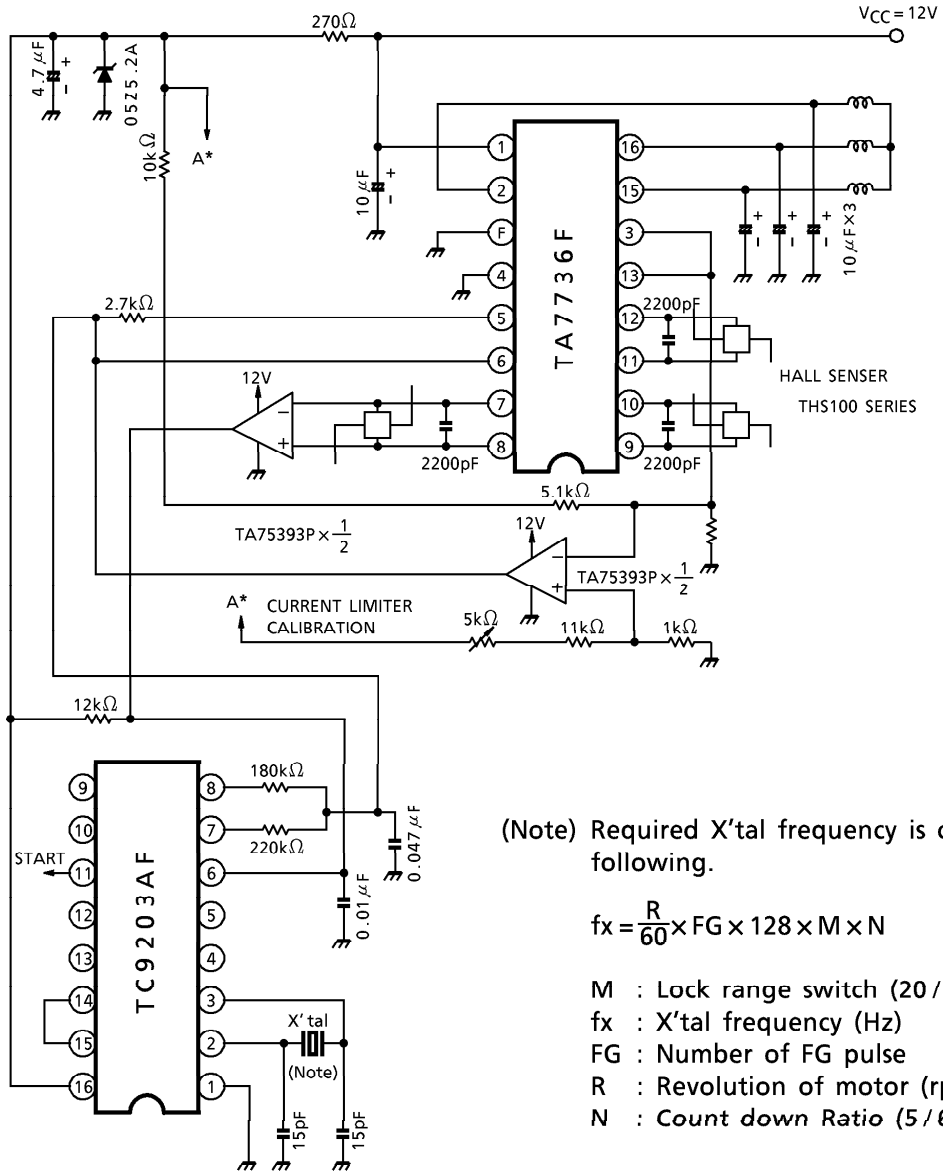

(Note) Required X'tal frequency is calculated by following.

$$f_x = \frac{R}{60} \times FG \times 128 \times M \times N$$

- M : Lock range switch (20 / 27)
- f_x : X'tal frequency (Hz)
- FG : Number of FG pulse
- R : Revolution of motor (rpm)
- N : Count down Ratio (5 / 6 / 12)

OUTLINE DRAWING
DIP16-P-300-2.54A

Unit : mm

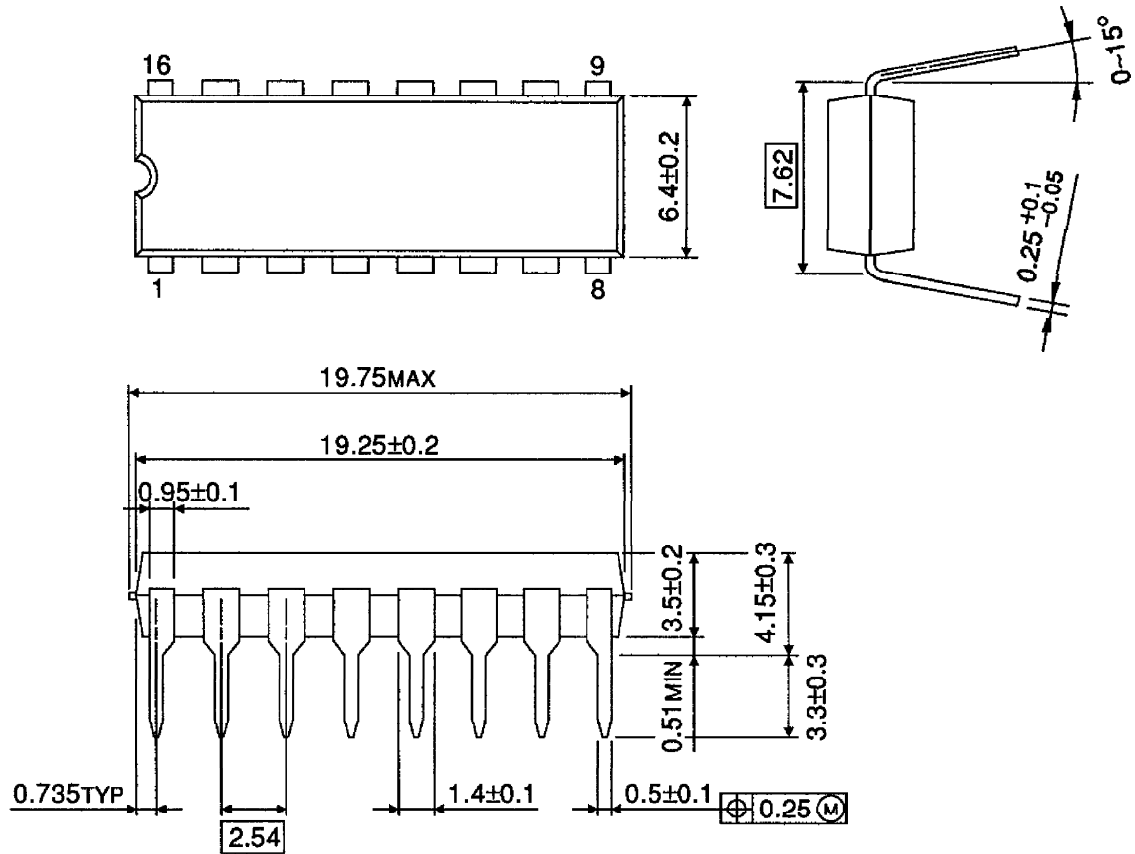

Weight : 1.11g (Typ.)

OUTLINE DRAWING
HSOP16-P-300-1.00

Unit : mm

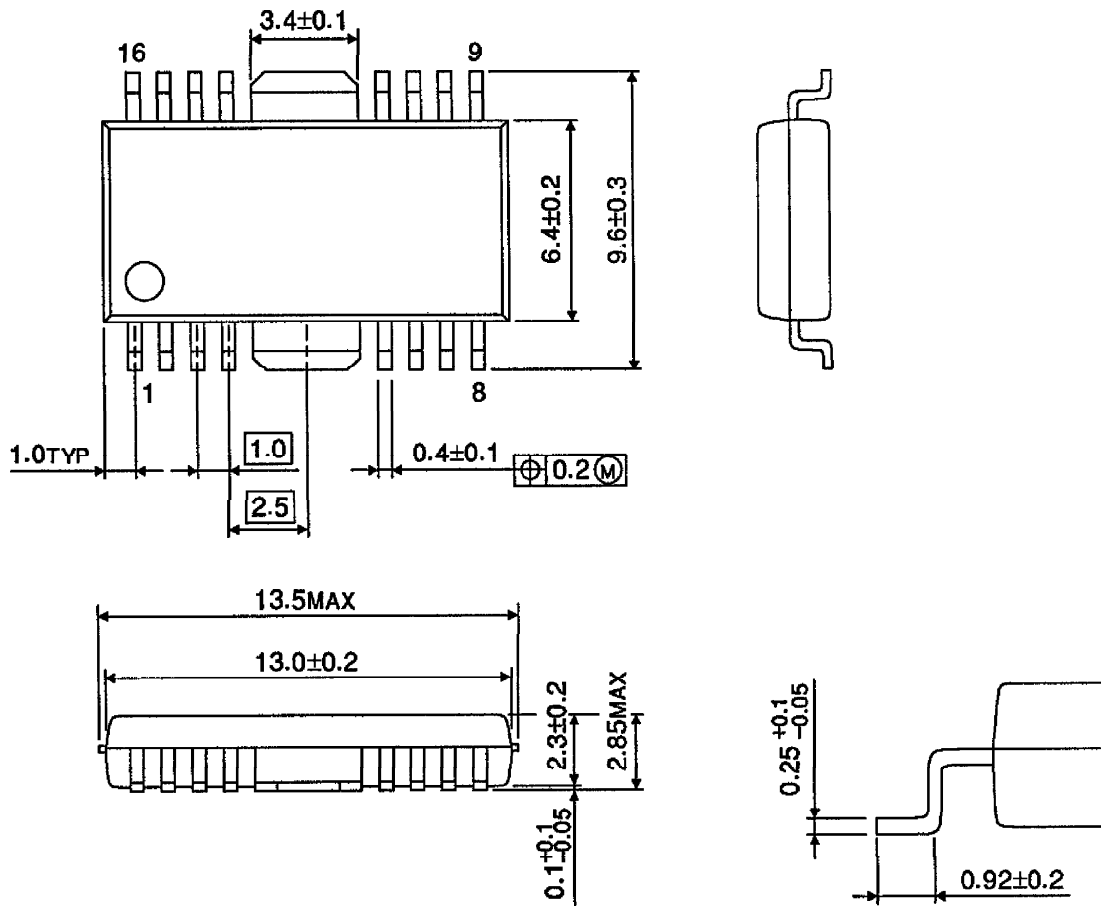

Weight : 0.50g (Typ.)