

Silicon NPN Power Transistors

2SC5149

DESCRIPTION

- With TO-3P(H)IS package
- High speed
- High voltage
- Low saturation voltage
- Built-in damper diode

APPLICATIONS

- Horizontal deflection output for high resolution display,colorTV
- High speed switching applications

PINNING

PIN	DESCRIPTION
1	Base
2	Collector
3	Emitter

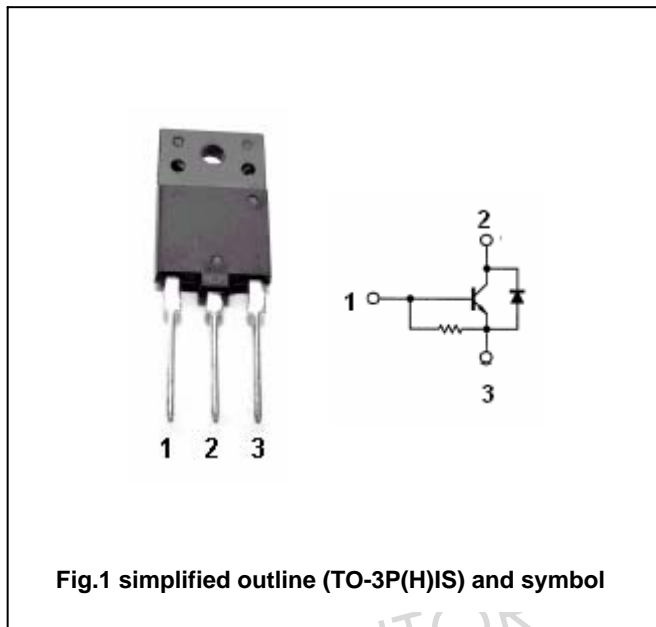

Fig.1 simplified outline (TO-3P(H)IS) and symbol

Absolute maximum ratings(Ta=25)

SYMBOL	PARAMETER	CONDITIONS	VALUE	UNIT
V _{CBO}	Collector-base voltage	Open emitter	1500	V
V _{CEO}	Collector-emitter voltage	Open base	600	V
V _{EBO}	Emitter-base voltage	Open collector	5	V
I _C	Collector current		8	A
I _{CM}	Collector current-Peak		16	A
I _B	Base current		4	A
P _T	Total power dissipation	T _C =25	50	W
T _j	Junction temperature		150	
T _{stg}	Storage temperature		-55~150	

Silicon NPN Power Transistors

2SC5149

CHARACTERISTICS

T_j=25 unless otherwise specified

SYMBOL	PARAMETER	CONDITIONS	MIN	TYP.	MAX	UNIT
V _{(BR)EBO}	Emitter-base breakdown voltage	I _C =400mA ; I _B =0	5			V
V _{CEsat}	Collector-emitter saturation voltage	I _C =5A ; I _B =1.3A			5	V
V _{BEsat}	Base-emitter saturation voltage	I _C =5A ; I _B =1.3A		1	1.3	V
I _{CBO}	Collector cut-off current	V _{CB} =1500V ; I _E =0			1	mA
I _{EBO}	Emitter cut-off current	V _{EB} =5V ; I _C =0	66		200	mA
h _{FE-1}	DC current gain	I _C =1A ; V _{CE} =5V	8		25	
h _{FE-2}	DC current gain	I _C =5A ; V _{CE} =5V	3.8		8	
C _{ob}	Collector output capacitance	I _E =0 ; V _{CB} =10V, f=1MHz		110		pF
V _F	Forward voltage(damper diode)	I _F =5A		1.35	1.8	V
f _T	Transition frequency	I _E =0.1A ; V _{CE} =10V		2		MHz
Switching times (inductive load)						
t _s	Storage time	I _{CP} =5A ; I _{B1(end)} =1.1A f _H =31.5kHz		4	6	μs
t _f	Fall time			0.2	0.5	μs

Silicon NPN Power Transistors

2SC5149

PACKAGE OUTLINE

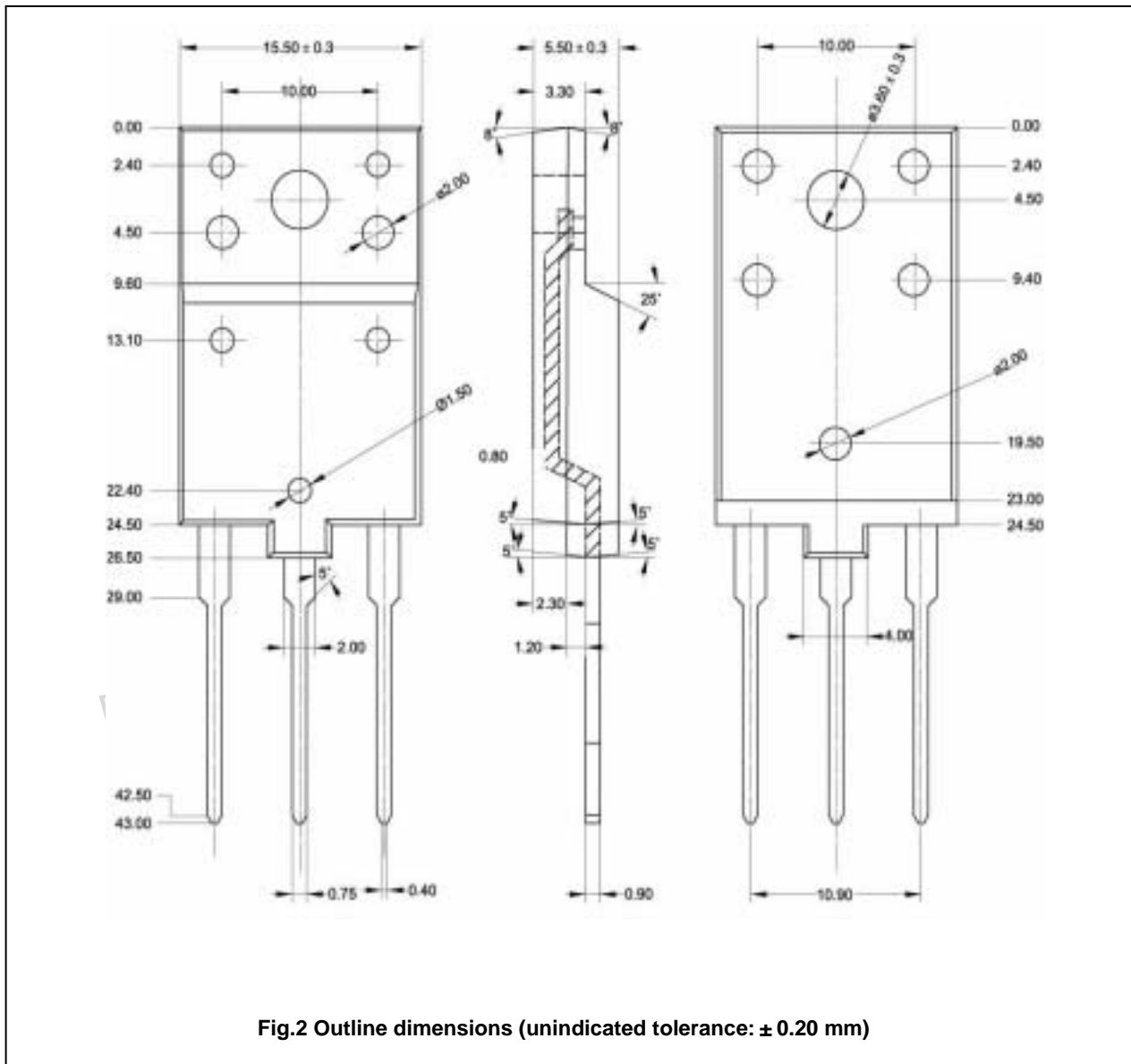

Silicon NPN Power Transistors

2SC5149

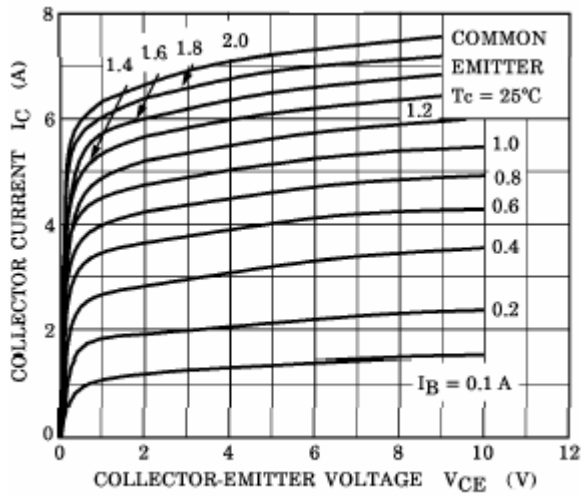

Fig.3 Static Characteristic

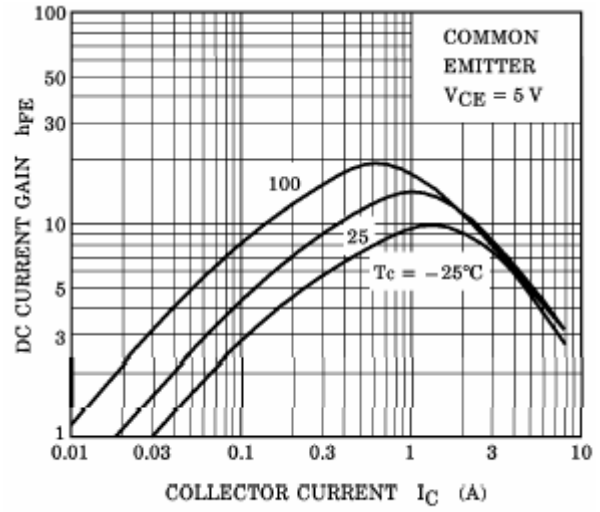

Fig.4 DC current Gain

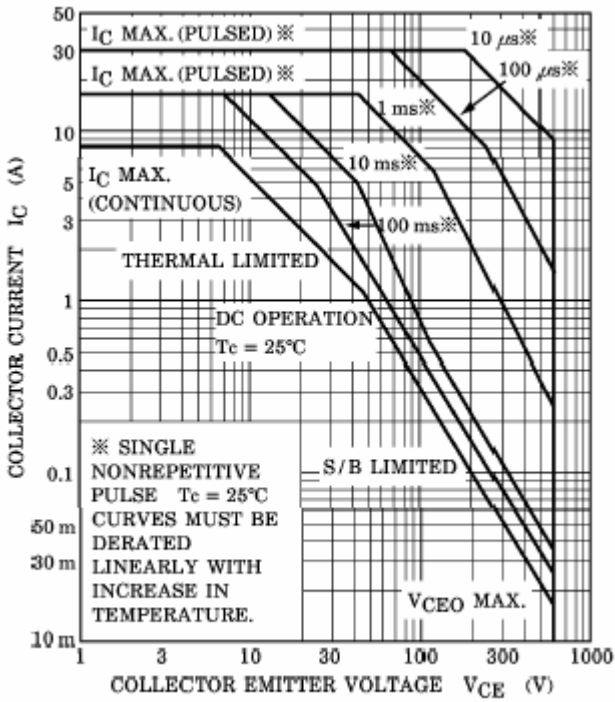

Fig.5 Safe Operating Area

EMICONDUTOR