

2SC5406, 2SC5406A

Silicon NPN triple diffusion mesa type

For horizontal deflection output

Features

- High breakdown voltage, and high reliability through the use of a glass passivation layer
- High-speed switching
- Wide area of safe operation (ASO)

Absolute Maximum Ratings (T_C=25°C)

Parameter	Symbol	Ratings	Unit	
Collector to base voltage	V _{CBO}	1500	V	
Collector to emitter voltage	V _{CES}	1500	V	
	V _{CEO}	600	V	
Emitter to base voltage	V _{EBO}	5	V	
Peak collector current	I _{CP}	20	A	
Collector current	I _C	14	A	
Base current	I _B	8	A	
Collector power dissipation	P _C	T _C =25°C	100	W
		T _a =25°C	3	
Junction temperature	T _j	150	°C	
Storage temperature	T _{stg}	-55 to +150	°C	

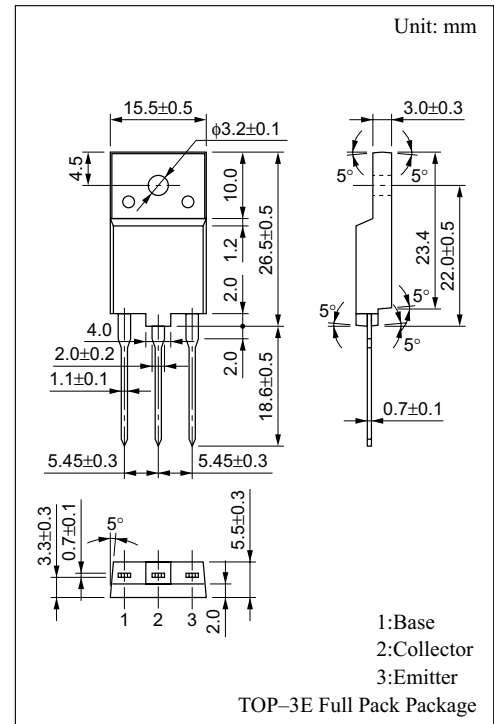

Electrical Characteristics (T_C=25°C)

Parameter	Symbol	Conditions	min	typ	max	Unit
Collector cutoff current	I _{CBO}	V _{CB} = 1000V, I _E = 0			50	μA
		V _{CB} = 1500V, I _E = 0			1	mA
Emitter cutoff current	I _{EBO}	V _{EB} = 5V, I _C = 0			50	μA
Forward current transfer ratio	h _{FE}	V _{CE} = 5V, I _C = 7A	5		12	
Collector to emitter saturation voltage	V _{CE(sat)}	I _C = 7A, I _B = 1.75A			3	V
Base to emitter saturation voltage	V _{BE(sat)}	I _C = 7A, I _B = 1.75A			1.5	V
Transition frequency	f _T	V _{CE} = 10V, I _C = 0, f = 0.5MHz		3		MHz
Storage time	t _{stg}	I _C = 7A, I _{B1} = 1.75A, I _{B2} = -3.5A			4.0	μs
Fall time	t _f				0.3	μs

$P_C - T_a$

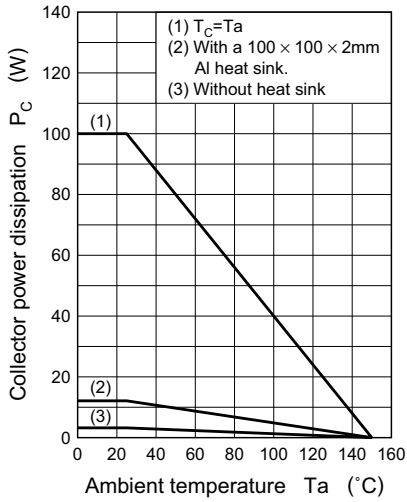

Area of safe operation (ASO)

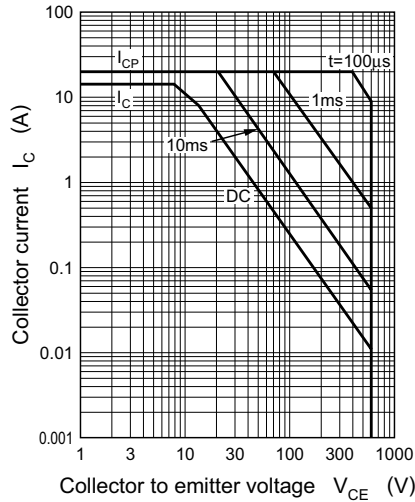

Area of safe operation, horizontal operation ASO

