

Silicon NPN Darlington Power Transistors

TIP140/141/142

DESCRIPTION

- With TO-3PN package
- DARLINGTON
- High DC current gain
- Complement to type TIP145/146/147

APPLICATIONS

- Designed for general-purpose amplifier and low frequency switching applications.

PINNING

PIN	DESCRIPTION
1	Base
2	Collector;connected to mounting base
3	Emitter

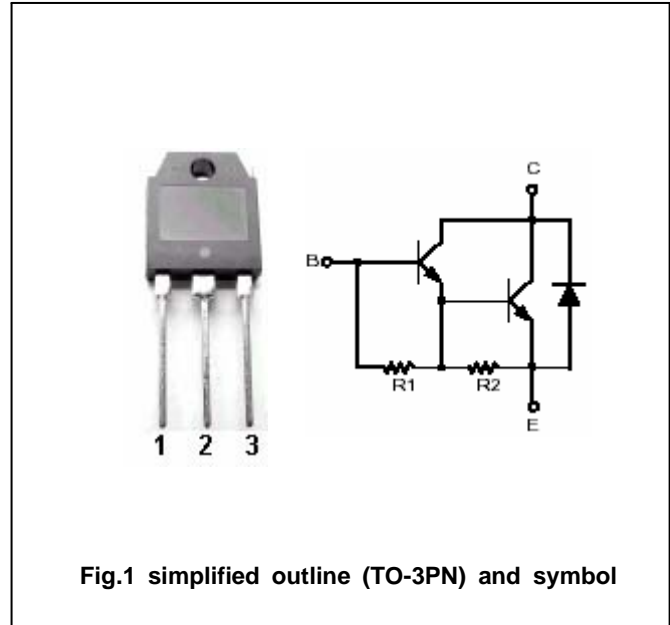

Fig.1 simplified outline (TO-3PN) and symbol

Absolute maximum ratings(Tc=25)

SYMBOL	PARAMETER	CONDITIONS	VALUE	UNIT
V _{CBO}	Collector-base voltage	TIP140	60	V
		TIP141	80	
		TIP142	100	
V _{CEO}	Collector-emitter voltage	TIP140	60	V
		TIP141	80	
		TIP142	100	
V _{EBO}	Emitter-base voltage	Open collector	5	V
I _C	Collector current-DC		10	A
I _{CM}	Collector current-Pulse		15	A
I _B	Base current-DC		0.5	A
P _C	Collector power dissipation	T _C =25	125	W
T _j	Junction temperature		150	
T _{stg}	Storage temperature		-65~150	

THERMAL CHARACTERISTICS

SYMBOL	PARAMETER	MAX	UNIT
R _{th j-c}	Thermal resistance junction to case	1.0	/W
R _{th j-A}	Thermal resistance case to ambient	35.7	/W

Silicon NPN Darlington Power Transistors

TIP140/141/142

CHARACTERISTICS

T_j=25 unless otherwise specified

SYMBOL	PARAMETER	CONDITIONS	MIN	TYP.	MAX	UNIT	
V _{CEO(SUS)}	Collector-emitter sustaining voltage	TIP140	I _C =30mA, I _B =0	60			V
		TIP141		80			
		TIP142		100			
V _{CEsat-1}	Collector-emitter saturation voltage	I _C =5A, I _B =10mA			2.0	V	
V _{CEsat-2}	Collector-emitter saturation voltage	I _C =10A, I _B =40mA			3.0	V	
V _{BEsat}	Base-emitter saturation voltage	I _C =10A, I _B =40mA			3.5	V	
V _{BE}	Base-emitter on voltage	I _C =10A; V _{CE} =4V			3.0	V	
I _{CBO}	Collector cut-off current	TIP140			1	mA	
		TIP141					V _{CB} =80V, I _E =0
		TIP142					V _{CB} =100V, I _E =0
I _{CEO}	Collector cut-off current	TIP140			2	mA	
		TIP141					V _{CE} =40V, I _B =0
		TIP142					V _{CE} =50V, I _B =0
I _{EBO}	Emitter cut-off current	V _{EB} =5V; I _C =0			2	mA	
h _{FE-1}	DC current gain	I _C =5A; V _{CE} =4V	1000				
h _{FE-2}	DC current gain	I _C =10A; V _{CE} =4V	500				

Switching times

t _d	Delay time	V _{CC} = 30 V, I _C = 5.0 A, I _B = 20 mA Duty Cycle 20% I _{B1} = I _{B2} , R _C & R _B Varied, T _J = 25		0.15		μs
t _r	Rise time			0.55		μs
t _{stg}	Storage time			2.5		μs
t _f	Fall time			2.5		μs

Silicon NPN Darlington Power Transistors

TIP140/141/142

PACKAGE OUTLINE

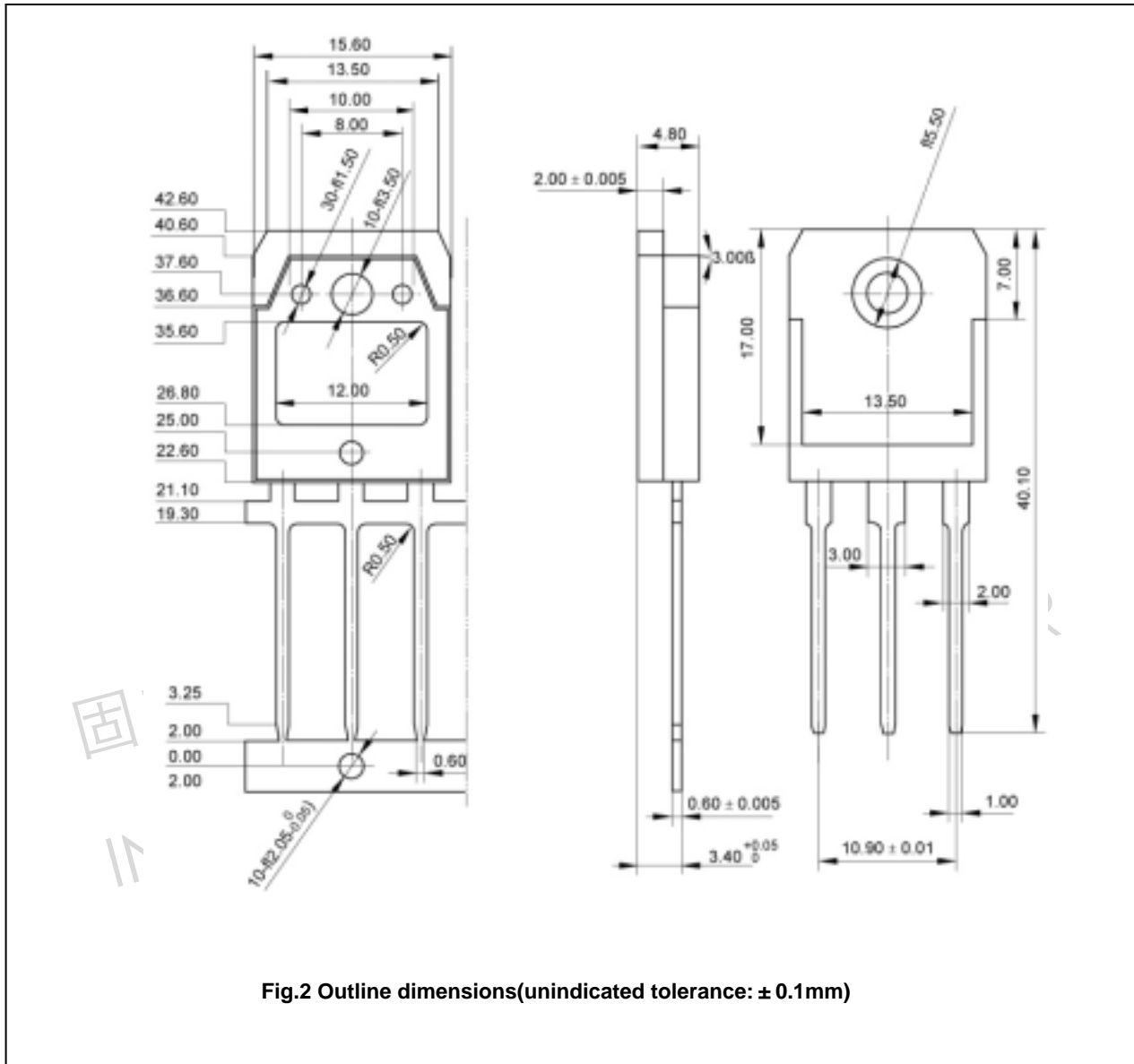

Fig.2 Outline dimensions(unindicated tolerance: $\pm 0.1\text{mm}$)

Silicon NPN Darlington Power Transistors

TIP140/141/142

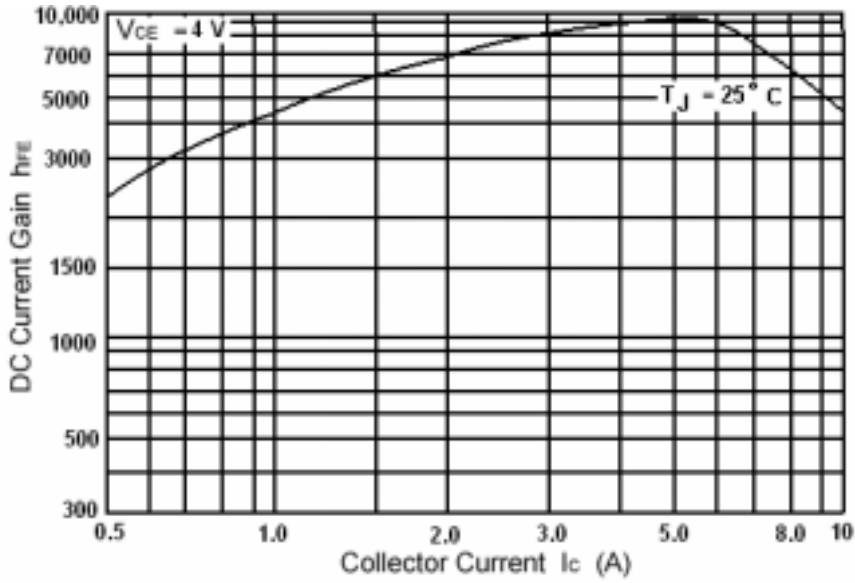

Fig.3 DC current Gain

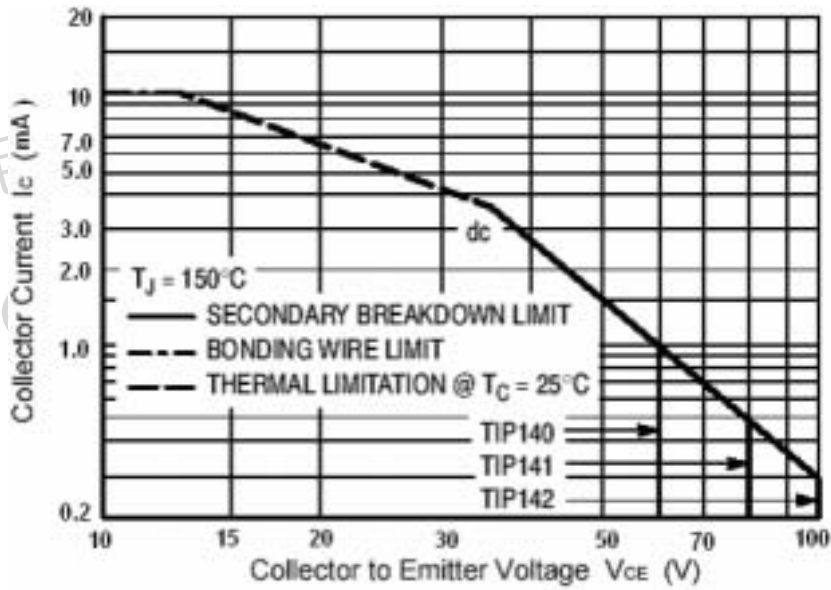

Fig.4 Safe Operating Area