

TOSHIBA Bipolar Linear Integrated Circuit Silicon Monolithic

TA8259H

Max Power 37 W BTL × 4CH Audio Power IC

The TA8259H is 4 ch BTL audio power amplifier for car audio application.

This IC can generate more high power: P_{OUT MAX} = 37 W as it is included the pure complementary PNP and NPN transistor output stage.

It is designed low distortion ratio for 4 ch BTL audio power amplifier, built-in Stand-by Function, Muting Function, Clip detector, and diagnosis circuit.

Additionally, the AUX. amplifier is built-in, it can make the beep signal etc. output to 2 channels (OUT1 and 4).

It contains various kind of protectors for car audio use.

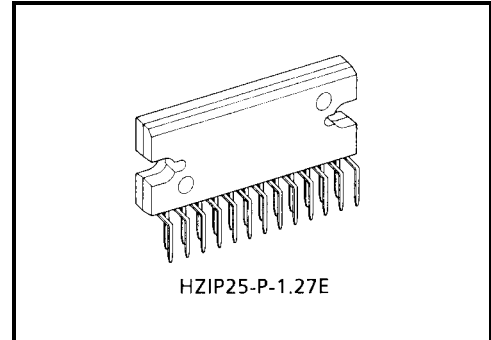

Weight: 9.8 g (typ.)

Features

- High power
 - : P_{OUT MAX} (1) = 37 W (typ.)
(V_{CC} = 14.4 V, JEITA max, R_L = 4 Ω)
 - : P_{OUT MAX} (2) = 35 W (typ.)
(V_{CC} = 13.7 V, JEITA max, R_L = 4 Ω)
 - : P_{OUT} (1) = 24 W (typ.)
(V_{CC} = 14.4 V, f = 1 kHz, THD = 10%, R_L = 4 Ω)
 - : P_{OUT} (2) = 21 W (typ.)
(V_{CC} = 13.2 V, f = 1 kHz, THD = 10%, R_L = 4 Ω)
- Built-in clip detector & diagnosis circuit. (pin 25)
- Low distortion ratio
 - : THD = 0.02% (typ.)
(V_{CC} = 13.2 V, f = 1 kHz, P_{OUT} = 5 W, R_L = 4 Ω)
- Low noise
 - : V_{NO} = 0.16 mV_{rms} (typ.)
(V_{CC} = 13.2 V, R_g = 0 Ω, G_V = 34dB, BW = 20 Hz~20 kHz)
- Built-in stand-by switch function (pin 2)
- Built-in muting function (pin 24)
- Built-in AUX. amplifier from single input (pin 16) to 2 channels output : OUT1 and 4
- Built-in various protection circuit
 - : Thermal shut down, over voltage, out to GND, out to V_{CC}, out to out short
- Operating supply voltage: V_{CC (opr)} = 9~18 V

Block Diagram

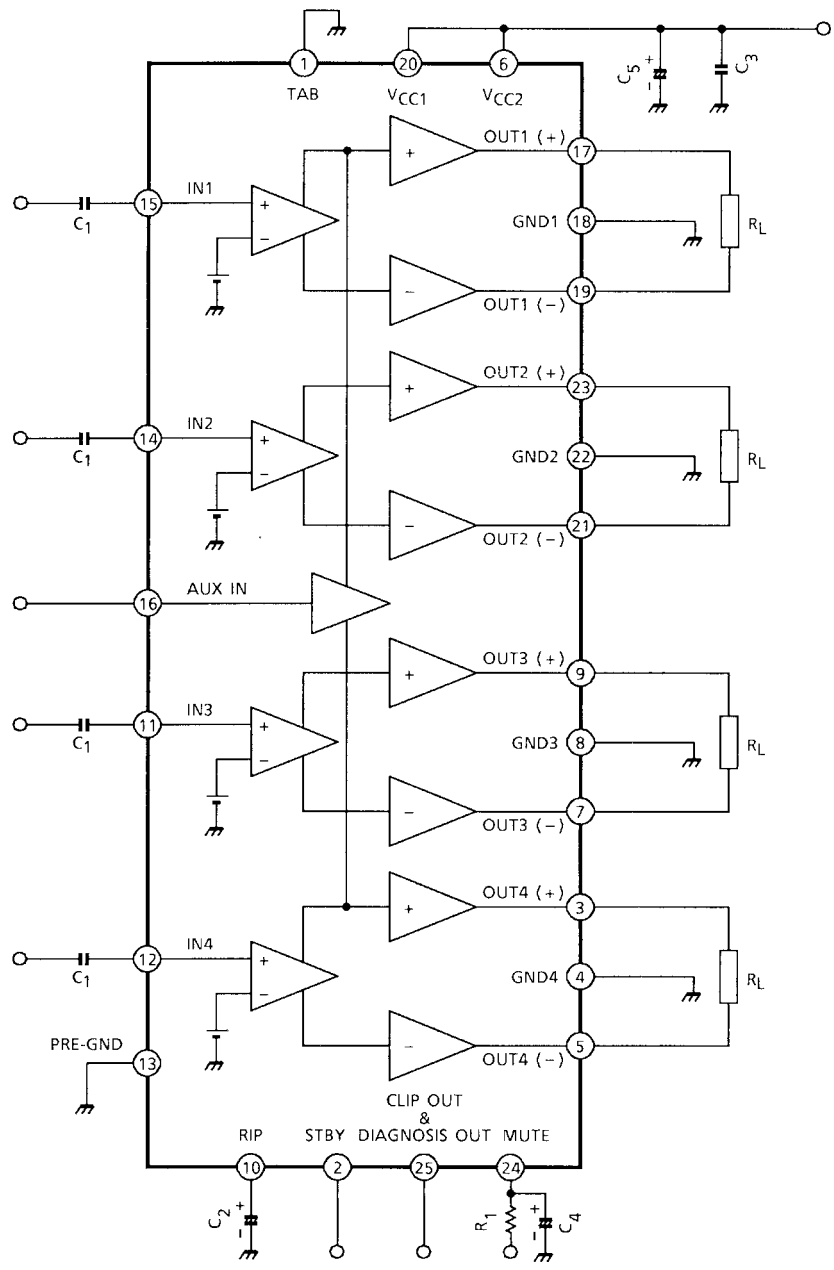

Caution and Application Method (description is made only on the single channel)

1. Voltage gain adjustment

This IC has no NF (negative feedback) terminals. Therefore, the voltage gain can't be adjusted, but it makes the device a space and total costs saver.

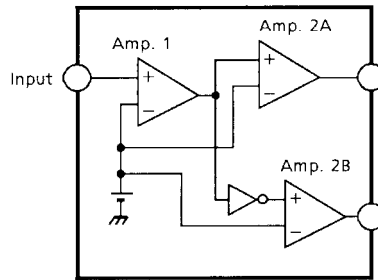

Figure 1 Block diagram

The voltage gain of Amp. 1 : $GV_1 = 8\text{dB}$

The voltage gain of Amp. 2A, B : $GV_2 = 20\text{dB}$

The voltage gain of BLT Connection : $GV(\text{BTL}) = 6\text{dB}$

Therefore, the total voltage gain is decided by expression below.

$$GV = GV_1 + GV_2 + GV(\text{BTL}) = 8 + 20 + 6 = 34\text{dB}$$

2. Stand-by SW function (pin 2)

By means of controlling pin 2 (Stand-by terminal) to High and Low, the power supply can be set to ON and OFF.

The threshold voltage of pin 2 is set at about 3 V_{BE} (typ.), and the Power Supply current is about 2 μA (typ.) at the stand-by state.

Control voltage of pin 2: V (SB)

Stand-By	Power	V (SB) (V)
ON	OFF	0~1.5
OFF	ON	3~ V _{CC}

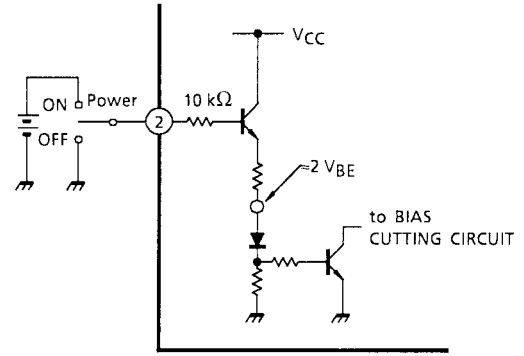

Figure 2 With pin 2 set to high, power is turned ON

Adjustage of stand-by SW

- (1) Since V_{CC} can directly be controlled to ON or OFF by the microcomputer, the switching relay can be omitted.
- (2) Since the control current is microscopic, the switching relay of small current capacity is satisfactory for switching

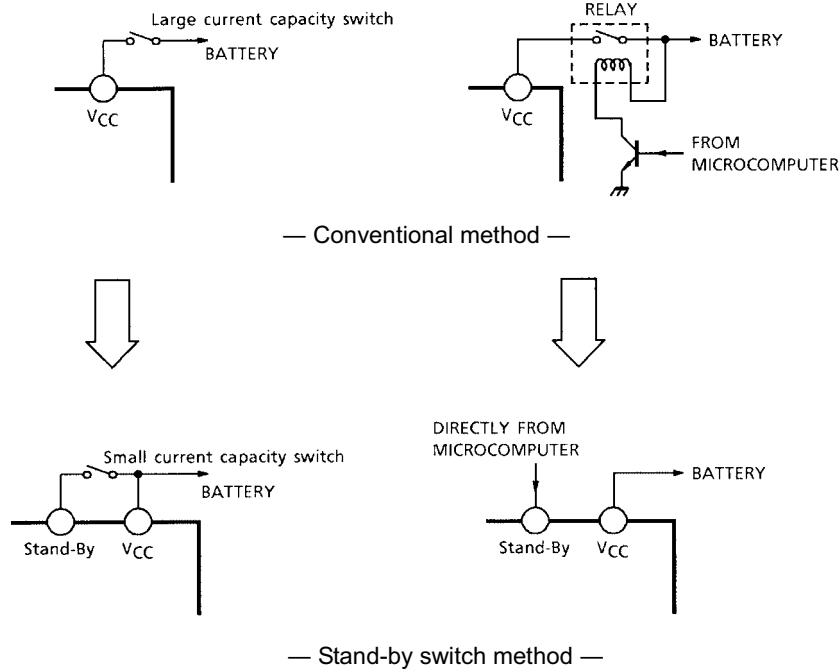

Figure 3

3. Muting function (pin 24)

By means of controlling pin 24 less than 0.5 V, it can make the audio muting condition. The muting time constant is decided by R₁ and C₄ and these parts is related the pop noise at power ON/OFF. The series resistance; R₁ must be set up less than 15 kΩ, we recommend 10 kΩ. The muting function have to be controlled by a transistor, FET and μ-COM port which has I_{MUTE} ≥ 250 μA ability. Terminal 24 must not be pulled up and it shall be controlled by OPEN/LOW.

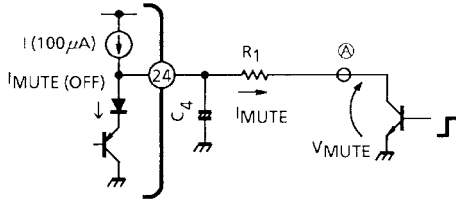

Figure 4 Muting function

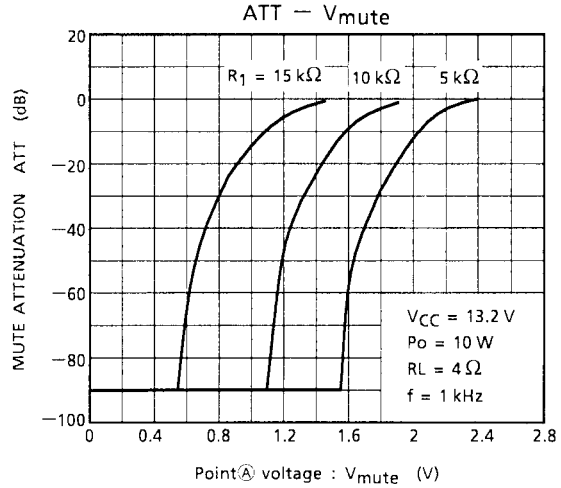

Figure 5 Mute attenuation-V_{mute} (V)

4. AUX. input (pin 16)

The pin 16 is for input terminal of AUX. amplifier. The total gain is 0dB by using of AUX. amplifier. Therefore, the μ-COM can directly drive the AUX. amplifier. BEEP sound or voice synthesizer signal can be input to pin 16 directly.

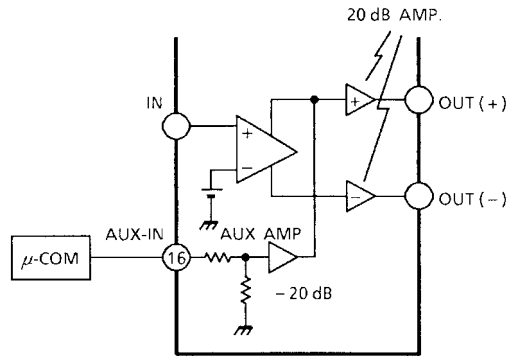
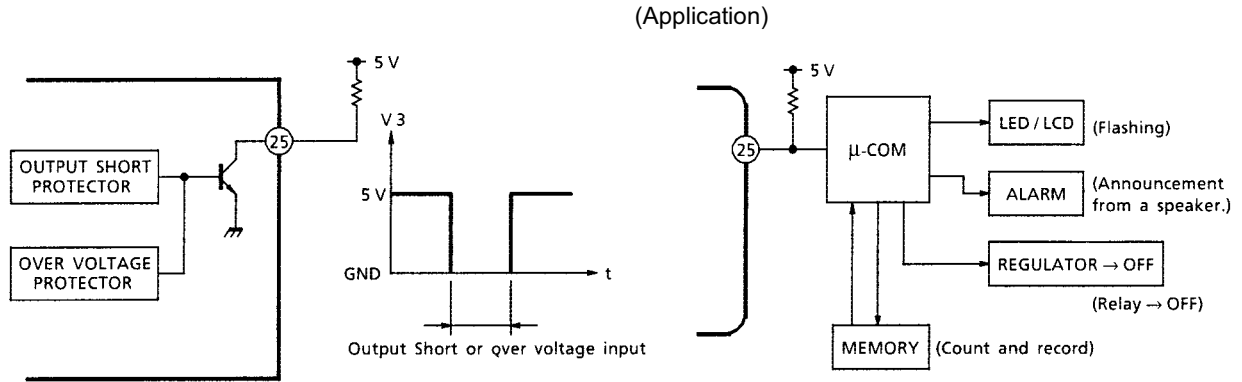

Figure 6 AUX input

5. Diagnosis output (pin 25)

The diagnosis output terminal of pin 25 has open collector output structure on chip as shown in Figure 7. In unusual case that output terminal of Power Amp. is condition of output to VCC or output to GND short and over voltage input mode, it is possible to protect all the system of apparatus as well as power IC protection.

In case of being unused this function, use this IC as open-connection on pin 25.



pin 25: Open collector output (active low)

Figure 7

6. Output clip detection function (pin 25)

The output clip detection terminal of pin 25 has the open collector output structure on chip as shown in Figure 8. In case that the output waveform is clipping, the clip detection circuit is operated and NPN Tr. is turned on.

It is possible to improve the audio quality with controlling the volume, tone control circuit through L.P.F. smoothing circuit as shown in Figure 8.

In case of being unused this function, use this IC as open connection on pin 25.

(Application)

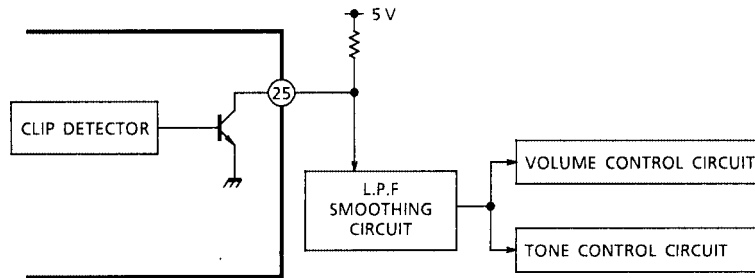

pin 25: Open collector output (active low)

Figure 8

(A) Output (AC wave form)

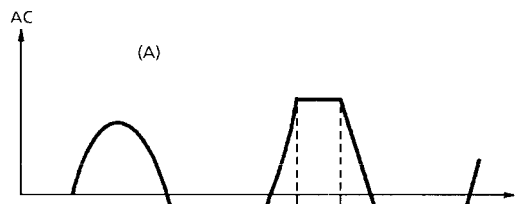

(B) Clip detector circuit (internal)

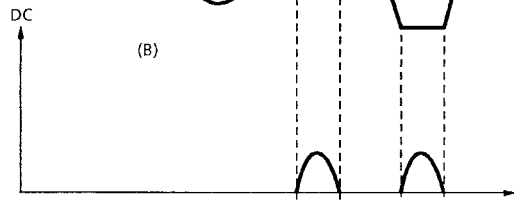

(C) Clip DET. terminal (pin 25)

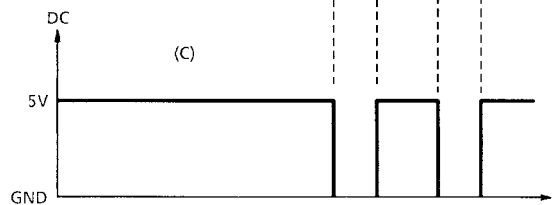

Figure 9

7. Cross talk

The cross talk characteristics of the IC is not good between OUT1 and 2, OUT3 and 4.
So we recommend to use by below method.

OUT1, 2	L-ch (or R-ch)
OUT3, 4	R-ch (or L-ch)

And, please refer to below table in case of applying the AUX. IN because it is out to OUT1 and 4.

ex) in case of the Signal from AUX. IN to front speakers.

OUT1	Front	L-ch (or R-ch)	AUX. OUT
OUT2	Rear		—
OUT3	Rear	R-ch (or L-ch)	—
OUT4	Front		AUX. OUT

Maximum Ratings (Ta = 25°C)

Characteristics	Symbol	Rating	Unit
Peak supply voltage (0.2 s)	V _{CC (surge)}	50	V
DC supply voltage	V _{CC (DC)}	25	V
Operating supply voltage	V _{CC (opr)}	18	V
Output current (peak)	I _{O (peak)}	9	A
Power dissipation	P _{D (Note 1)}	250	W
Operating temperature	T _{opr}	-40~85	°C
Storage temperature	T _{stg}	-55~150	°C

Note 1: Package thermal resistance $\theta_{j-T} = 0.5^{\circ}\text{C/W}$ (typ.)
(Ta = 25°C, with infinite heat sink)

Electrical Characteristics

(unless otherwise specified, V_{CC} = 13.2 V, f = 1 kHz, R_L = 4 Ω, Ta = 25°C)

Characteristics	Symbol	Test Circuit	Test Condition	Min	Typ.	Max	Unit
Quiescent current	I _{CCQ}	—	V _{IN} = 0	—	200	400	mA
Output power	P _{OUT MAX (1)}	—	V _{CC} = 14.4 V, MAX power	—	37	—	W
	P _{OUT MAX (2)}	—	V _{CC} = 13.7 V, MAX power	—	35	—	
	P _{OUT (1)}	—	V _{CC} = 14.4 V, THD = 10%	—	24	—	
	P _{OUT (2)}	—	THD = 10%	19	21	—	
Total harmonic distortion	THD	—	P _{OUT} = 5 W	—	0.02	0.2	%
Voltage gain	G _V	—	V _{OUT} = 0.775 V _{rms} (0dBm)	32	34	36	dB
Voltage gain ratio	ΔG _V	—	V _{OUT} = 0.775 V _{rms} (0dBm)	-1.0	0	1.0	dB
Output noise voltage	V _{NO (1)}	—	R _g = 0 Ω, DIN45405	—	0.18	—	mV _{rms}
	V _{NO (2)}	—	R _g = 0 Ω, BW = 20 Hz~20 kHz	—	0.16	0.35	
Ripple rejection ratio	R.R.	—	f _{rip} = 100 Hz, R _g = 620 Ω V _{rip} = 0.775 V _{rms} (0dBm)	40	50	—	dB
Cross talk	C.T.	—	R _g = 620 Ω, V _{OUT} = 0.775 V _{rms} (0dBm)	—	62	—	dB
Output offset voltage	V _{OFFSET}	—	—	-100	0	100	mV
Input resistance	R _{IN}	—	—	—	30	—	kΩ
Stand-by current	I _{SB}	—	Stand-by condition	—	2	10	μA
Stand-by control voltage	V _{SB H}	—	Power: on	3.0	—	V _{CC}	V
	V _{SB L}	—	Power: off	0	—	1.5	
Mute control voltage (Note 2)	V _{M H}	—	Mute: off	OPEN			—
	V _{M L}	—	Mute: on, R ₁ = 10 kΩ	0	—	0.5	V
Mute attenuation	ATT M	—	Mute: on, V _{OUT} = 7.75 V _{rms} (20dBm) at Mute: off.	80	90	—	dB

Note 2: Muting function have to be controlled by open and Low Logic, which Logic is a transistor, FET and μ-COM port of I_{MUTE} > 250 μA ability.

This means that the Mute control terminal: pin 24 must not be pulled-up.

Test Circuit

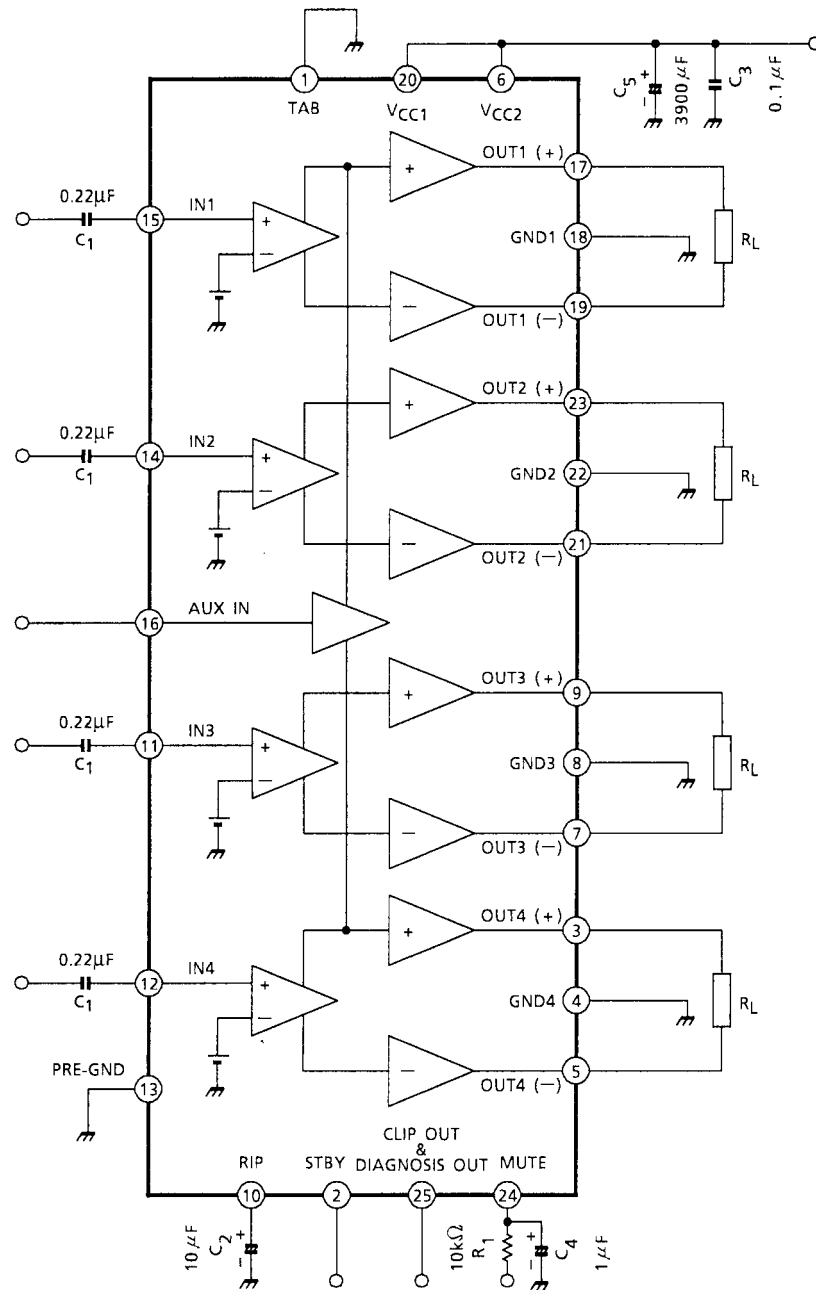

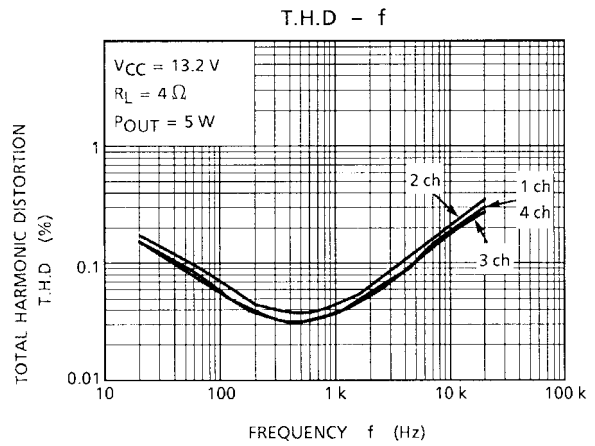
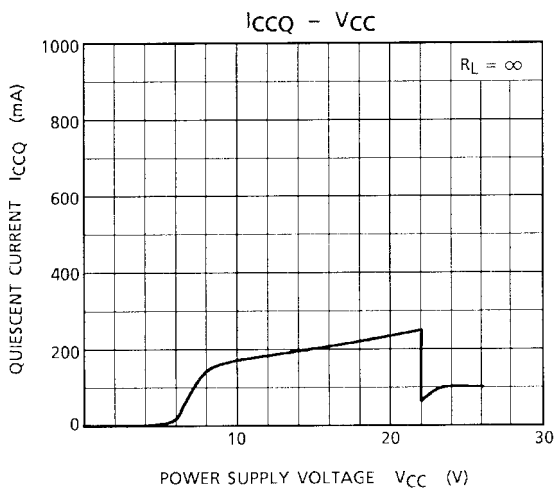
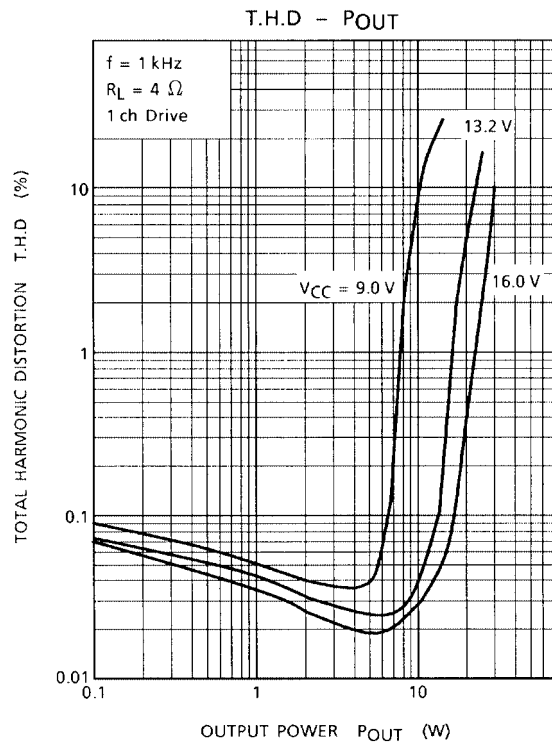
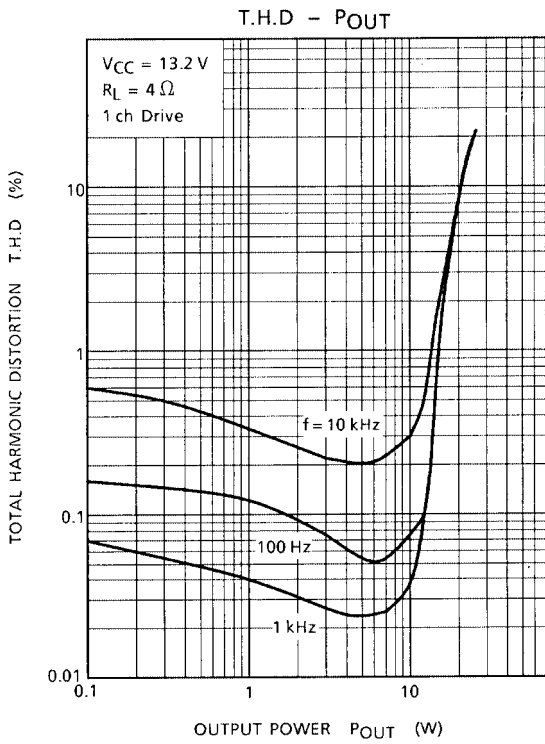

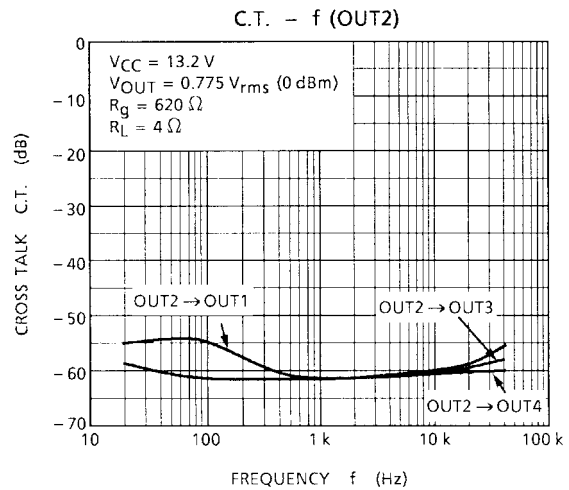
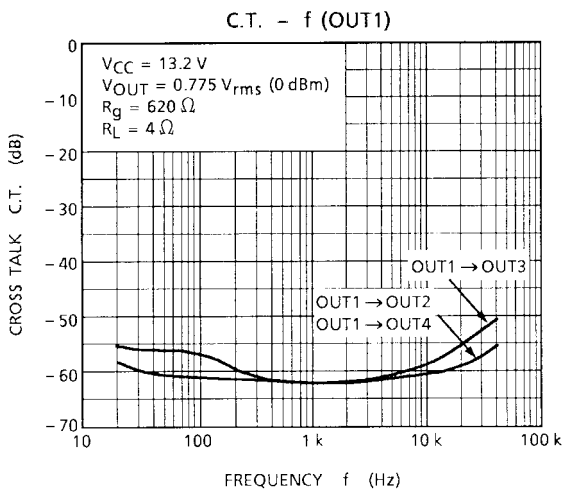
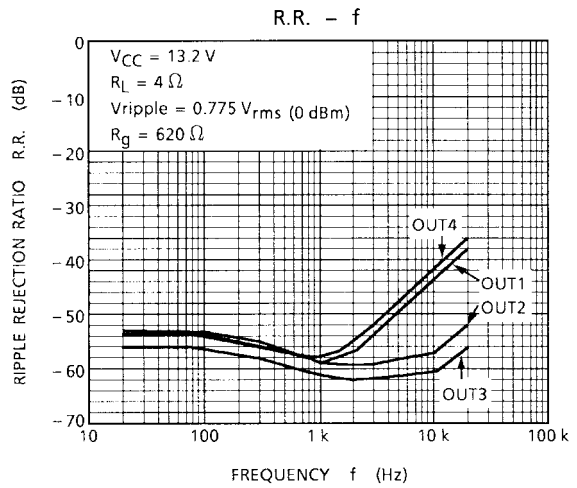
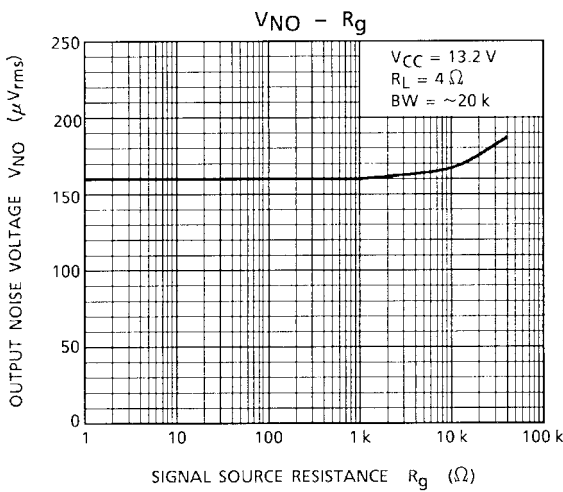
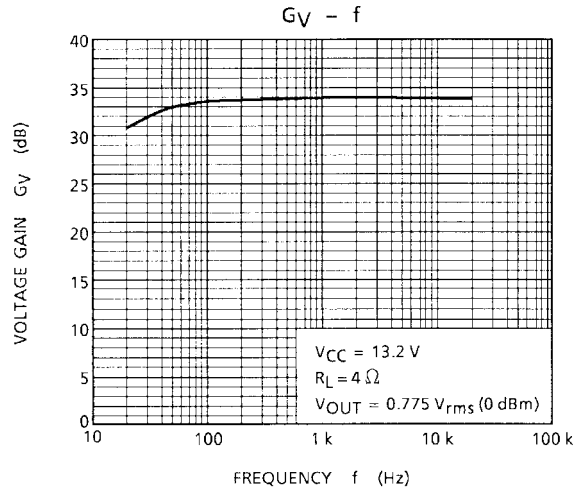
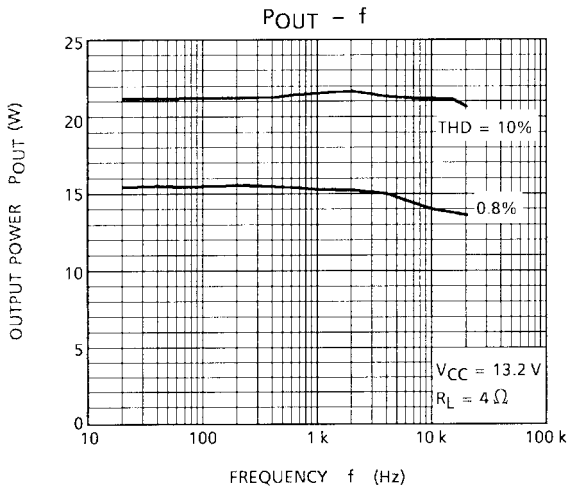

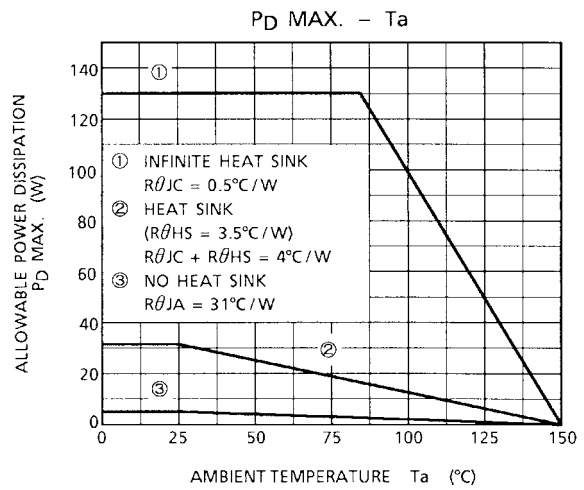
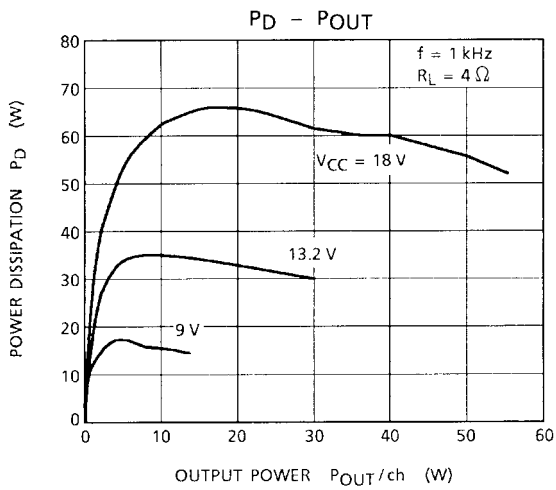
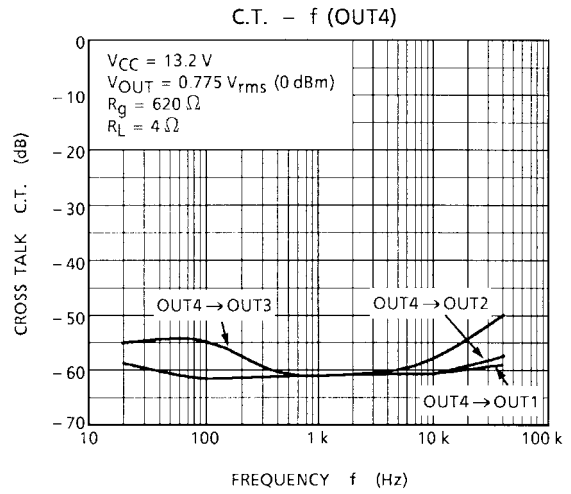
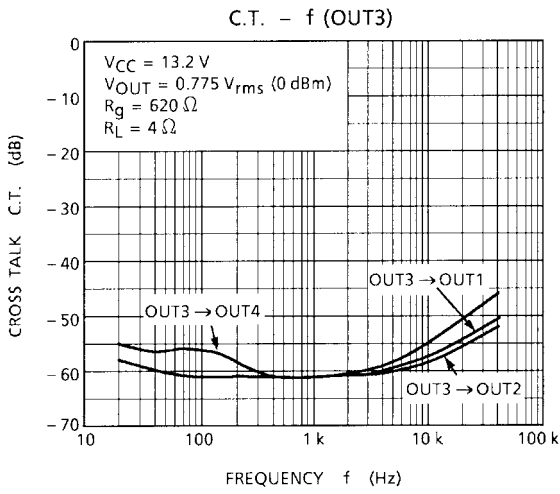

Package Dimensions

HZIP25-P-1.27E

Unit : mm

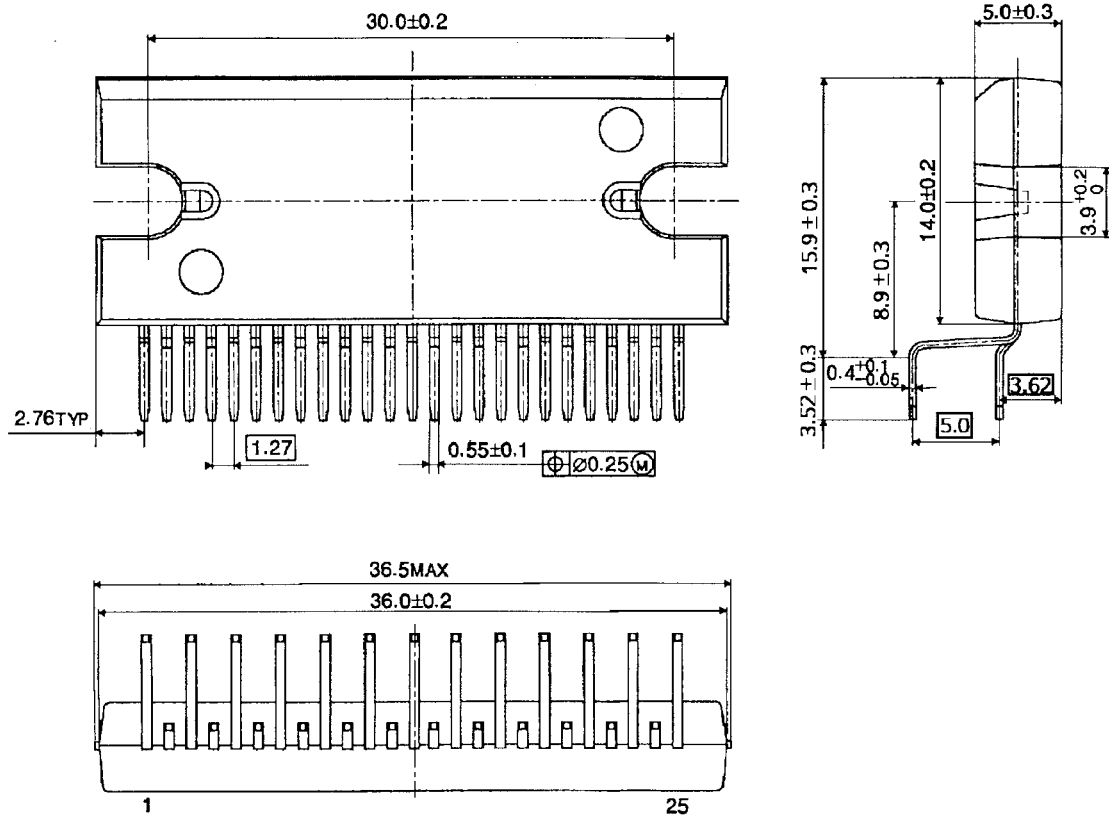

Weight: 9.8 g (typ.)

RESTRICTIONS ON PRODUCT USE

000707EBF

- TOSHIBA is continually working to improve the quality and reliability of its products. Nevertheless, semiconductor devices in general can malfunction or fail due to their inherent electrical sensitivity and vulnerability to physical stress. It is the responsibility of the buyer, when utilizing TOSHIBA products, to comply with the standards of safety in making a safe design for the entire system, and to avoid situations in which a malfunction or failure of such TOSHIBA products could cause loss of human life, bodily injury or damage to property.
In developing your designs, please ensure that TOSHIBA products are used within specified operating ranges as set forth in the most recent TOSHIBA products specifications. Also, please keep in mind the precautions and conditions set forth in the "Handling Guide for Semiconductor Devices," or "TOSHIBA Semiconductor Reliability Handbook" etc..
- The TOSHIBA products listed in this document are intended for usage in general electronics applications (computer, personal equipment, office equipment, measuring equipment, industrial robotics, domestic appliances, etc.). These TOSHIBA products are neither intended nor warranted for usage in equipment that requires extraordinarily high quality and/or reliability or a malfunction or failure of which may cause loss of human life or bodily injury ("Unintended Usage"). Unintended Usage include atomic energy control instruments, airplane or spaceship instruments, transportation instruments, traffic signal instruments, combustion control instruments, medical instruments, all types of safety devices, etc.. Unintended Usage of TOSHIBA products listed in this document shall be made at the customer's own risk.
- This product generates heat during normal operation. However, substandard performance or malfunction may cause the product and its peripherals to reach abnormally high temperatures.
The product is often the final stage (the external output stage) of a circuit. Substandard performance or malfunction of the destination device to which the circuit supplies output may cause damage to the circuit or to the product.
- The products described in this document are subject to the foreign exchange and foreign trade laws.
- The information contained herein is presented only as a guide for the applications of our products. No responsibility is assumed by TOSHIBA CORPORATION for any infringements of intellectual property or other rights of the third parties which may result from its use. No license is granted by implication or otherwise under any intellectual property or other rights of TOSHIBA CORPORATION or others.
- The information contained herein is subject to change without notice.