

# Quad Single Supply Operational Amplifiers

These internally compensated Norton operational amplifiers are designed specifically for single positive power supply applications found in industrial control systems and automotive electronics. Each device contains four independent amplifiers — making it ideal for applications such as active filters, multi-channel amplifiers, tachometers, oscillators and other similar usage.

- Single Supply Operation
- Internally Compensated
- Wide Unity Gain Bandwidth: 4.0 MHz Typical
- Low Input Bias Current: 50 nA Typical
- High Open-Loop Gain: 1000 V/V Minimum
- Large Output Voltage Swing:  $(V_{CC} - 1) V_{p-p}$

**MC3301 LM2900  
MC3401 LM3900**

**QUAD  
OPERATIONAL AMPLIFIERS**  
**SILICON MONOLITHIC  
INTEGRATED CIRCUIT**

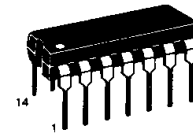

**N, P SUFFIX  
PLASTIC PACKAGE  
CASE 646**

**D SUFFIX  
PLASTIC PACKAGE  
CASE 751A  
(SO-14)**

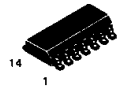

### PIN CONNECTIONS

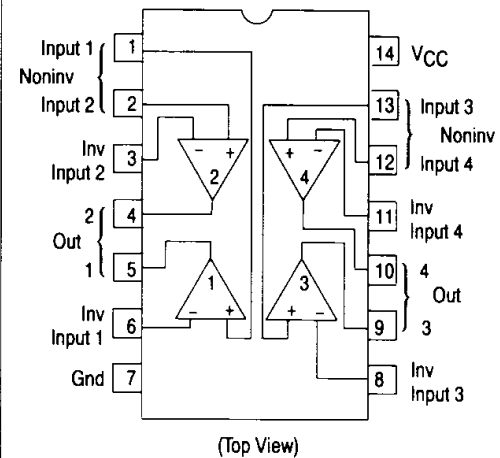

### MAXIMUM RATINGS

Rating	Symbol	LM2900/ LM3900	MC3301	MC3401	Unit
Supply Voltage	$V_{CC}$	+32	+28	+18	V
Input Current ( $I_{in+}$ or $I_{in-}$ )	$I_{in}$	5.0			mA
Output Current	$I_O$	50			mA
Power Dissipation ( $T_A = +25^\circ\text{C}$ ) Derate above $T_A = +25^\circ\text{C}$	$P_D$ $1/R_{\theta JA}$	625 5.0			mW mW/°C
Ambient Temperature Range LM2900 LM3900	$T_A$	-40 to +85 0 to +70	-40 to +85	0 to +70	°C
Storage Temperature Range	$T_{stg}$	-65 to +150			°C

### ORDERING INFORMATION

Device	Temperature Range	Package
LM3900D MC3401D	0° to +70°C	SO-14
LM3900N MC3401P		Plastic DIP
LM2900N MC3301P	-40° to +85°C	

# MC3301, MC3401, LM2900, LM3900

**ELECTRICAL CHARACTERISTICS** ( $V_{CC} = +15$  Vdc,  $R_L = 5.0$  k $\Omega$ ,  $T_A = +25^\circ\text{C}$  [each amplifier], unless otherwise noted.)

Characteristics	Symbol	LM2900			LM3900			MC3301			MC3401			Unit
		Min	Typ	Max	Min	Typ	Max	Min	Typ	Max	Min	Typ	Max	
Open-Loop Voltage Gain $f = 100$ Hz, $R_L = 5.0$ k $T_A = T_{low}$ to $T_{high}$ (Notes 1, 2)	$A_{VOL}$	1.2	2.0	—	1.2	2.0	—	1.2	2.0	—	1.2	2.0	—	V/mV
Input Resistance (Inverting Input)	$r_i$	—	1.0	—	—	1.0	—	—	1.0	—	0.1	1.0	—	M $\Omega$
Output Resistance	$r_o$	—	8.0	—	—	8.0	—	—	8.0	—	—	8.0	—	k $\Omega$
Input Bias Current (Inverting Input) $T_A = T_{low}$ to $T_{high}$ (Note 1)	$I_{IB}$	—	50	200	—	50	200	—	50	300	—	50	300	nA
Slew Rate ( $C_L = 100$ pF, $R_L = 2.0$ k) Positive Output Swing Negative Output Swing	SR	—	0.5	—	—	0.5	—	—	0.5	—	—	0.5	—	V/ $\mu$ s
Unity Gain Bandwidth	BW	—	4.0	—	—	4.0	—	—	4.0	—	—	4.0	—	MHz
Output Voltage Swing (Note 7) $V_{CC} = +15$ V, $R_L = 2.0$ k $V_{out High}$ ( $I_{in} = 0$ , $I_{in} = +0$ ) $V_{out Low}$ ( $I_{in} = 10$ $\mu$ A, $I_{in} = +0$ ) $V_{CC} = \text{Maximum Rating}$ , $R_L = \infty$ $V_{out High}$ ( $I_{in} = 0$ , $I_{in} = +0$ )	$V_{OH}$ $V_{OL}$ $V_{OH}$	13.5 — —	14.2 0.03 29.5	— 0.2 —	13.5 — —	14.2 0.03 29.5	— 0.2 —	13.5 — —	14.2 0.03 25.5	— 0.2 —	13.5 — —	14.2 0.03 15.5	— 0.2 —	V
Output Current Source Sink (Note 3) Low Level Output Current $I_{in} = 5.0$ $\mu$ A, $V_{OL} = 1.0$ V	$I_{Source}$ $I_{Sink}$ $I_{OL}$	6.0 0.5 —	10 0.87 5.0	— — —	6.0 0.5 —	10 0.87 5.0	— — —	5.0 0.5 —	10 0.87 5.0	5.0 0.5 —	5.0 0.5 —	10 0.87 5.0	— — —	mA
Supply Current (All Four Amplifiers) Noninverting Inputs Open Noninverting Inputs Grounded	$I_{DO}$ $I_{DG}$	— —	6.9 7.8	10 14	— —	6.9 7.8	10 14	— —	6.9 7.8	10 14	— —	6.9 7.8	10 14	mA
Power Supply Rejection ( $f = 100$ Hz)	PSR	—	55	—	—	55	—	—	55	—	—	55	—	dB
Mirror Gain ( $T_A = T_{low}$ to $T_{high}$ ; Notes 1, 4) $I_{in} = 20$ $\mu$ A $I_{in} = 200$ $\mu$ A	$A_i$	0.90 0.90	1.0 1.0	1.1 1.1	0.90 0.90	1.0 1.0	1.1 1.1	0.90 0.90	1.0 1.0	1.1 1.1	0.90 0.90	1.0 1.0	1.1 1.1	$\mu$ A
$\Delta$ Mirror Gain ( $T_A = T_{low}$ to $T_{high}$ ; Notes 1, 4) $20$ $\mu$ A $\leq I_{in} \leq 200$ $\mu$ A	$\Delta A_i$	—	2.0	5.0	—	2.0	5.0	—	2.0	5.0	—	2.0	5.0	%
Mirror Current ( $T_A = T_{low}$ to $T_{high}$ ; Notes 1, 5)		—	10	500	—	10	500	—	10	500	—	10	500	$\mu$ A
Negative Input Current (Note 6)		—	1.0	—	—	1.0	—	—	1.0	—	—	1.0	—	mA

- NOTES:**
- $T_{low} = -40^\circ\text{C}$  for LM2900, MC3301  
 $= 0^\circ\text{C}$  for LM3900, MC3401  
 $T_{high} = +85^\circ\text{C}$  for LM290, MC3301  
 $= +70^\circ\text{C}$  for LM3900, MC3401
  - Open-Loop voltage gain is defined as voltage gain from the inverting input to the output.
  - Sink current is specified for linear operation. When the device is used as a comparator (non-linear operation) where the inverting input is overdriven, the sink current (low level output current) capability is typically 5.0 mA.
  - This specification indicates the current gain of the current mirror which is used as the noninverting input.
  - Input  $V_{BE}$  match between the noninverting and inverting inputs occurs for a mirror current (noninverting input current) of approximately 10  $\mu$ A.
  - Clamp transistors are included to prevent the input voltages from swinging below ground more than approximately  $-0.3$  V. The negative input currents that may result from large signal overdrive with capacitive input coupling must be limited externally to values of approximately 1.0 mA. If more than one of the input terminals are simultaneously driven negative, maximum currents are reduced. Common mode biasing can be used to prevent negative input voltages.
  - When used as a noninverting amplifier, the minimum output voltage is the  $V_{BE}$  of the inverting input transistor.

# MC3301, MC3401, LM2900, LM3900

2

Figure 1. Open-Loop Voltage Gain versus Frequency

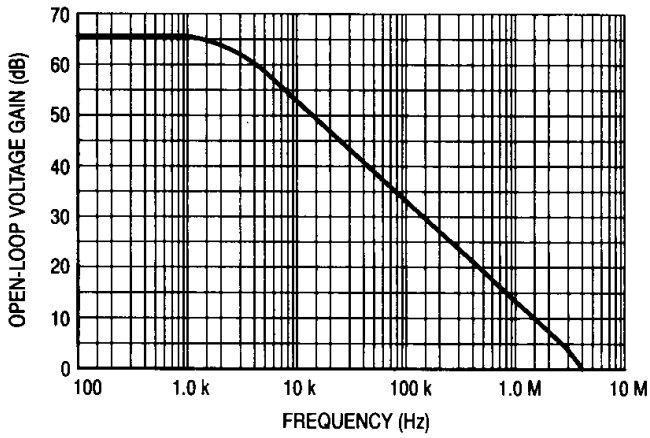

Figure 2. Open-Loop Voltage Gain versus Supply Voltage

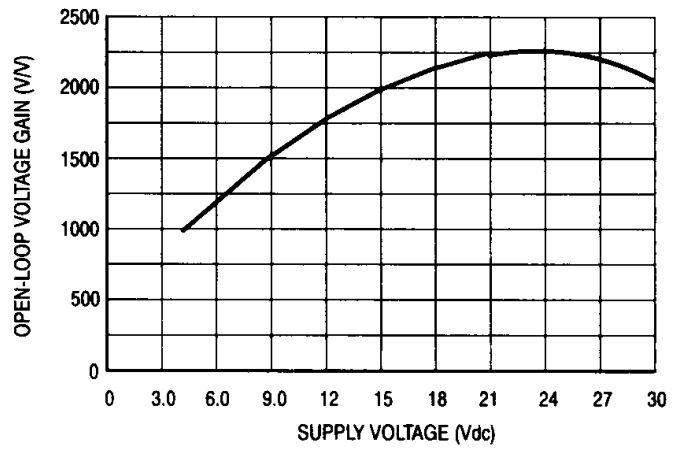

Figure 3. Output Resistance versus Frequency

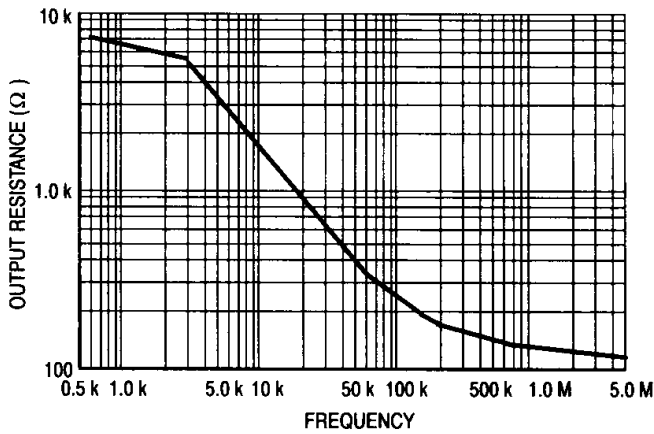

Figure 4. Supply Current versus Supply Voltage

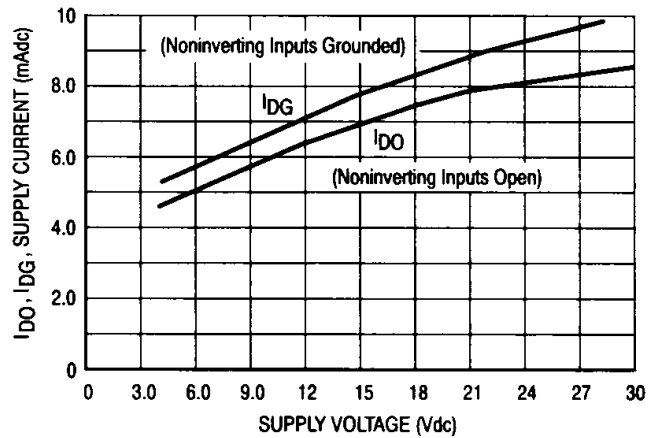

Figure 5. Linear Source Current versus Supply Voltage

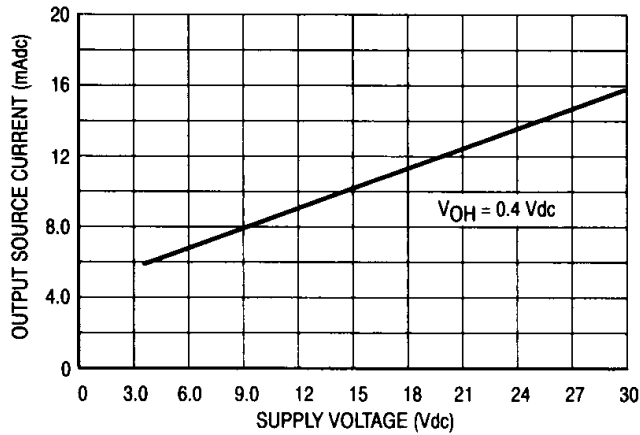
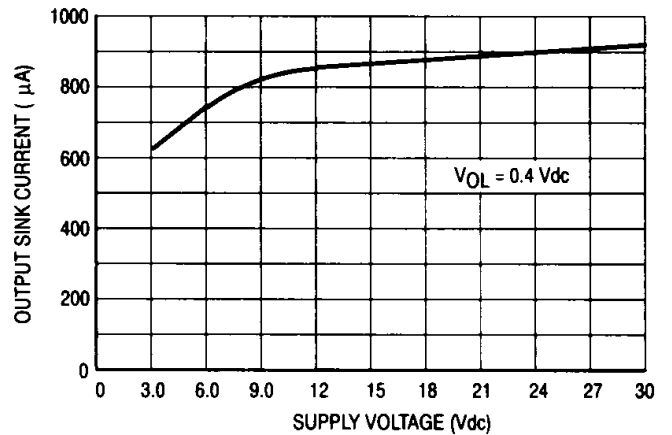

Figure 6. Linear Sink Current versus Supply Voltage



# MC3301, MC3401, LM2900, LM3900

## OPERATION AND APPLICATIONS

### Basic Amplifier

The basic amplifier is the common emitter stage shown in Figures 7 and 8. The active load  $I_1$  is buffered from the input transistor by a PNP transistor, Q4, and from the output by an NPN transistor, Q2. Q2 is biased Class A by the current source  $I_2$ . The magnitude of  $I_2$  (specified  $I_{sink}$ ) is a limiting factor in capacitively coupled linear operation at the output. The sink of

the device can be forced to exceed the specified level by keeping the output dc voltage above  $\approx 1.0$  V resulting in an increase in the distortion appearing at the output. Closed-loop stability is maintained by an on-the-chip 3-pF capacitor shown in Figure 10 on the following page. No external compensation is required.

Figure 7. Block Diagram

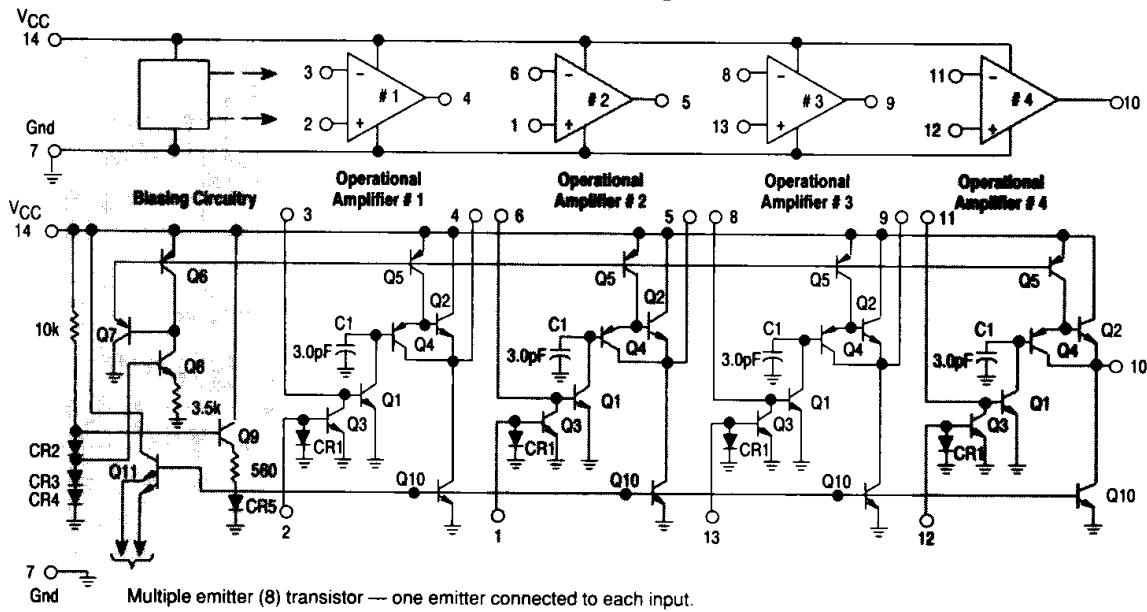

A noninverting input obtained by adding a current mirror as shown in Figure 9. Essentially all current which enters the noninverting input,  $I_{in}^+$ , flows through the diode CR1. The voltage drop across CR1 corresponds to this input current magnitude and this same voltage is applied to a matched device, Q3. Thus Q3 is biased to conduct an emitter current equal to  $I_{in}^+$ . Since the alpha current gain of Q3  $\approx 1$ , its

collector current is approximately equal to  $I_{in}^+$  also. In operation this current flows through an external feedback resistor which generates the output voltage signal. For inverting applications, the noninverting input is often used to set the dc quiescent level at the output. Techniques for doing this are discussed in the "Normal Design Procedure" section.

Figure 8. A Basic Gain Stage

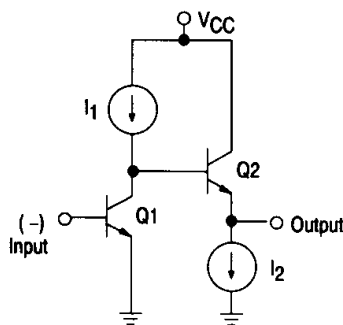
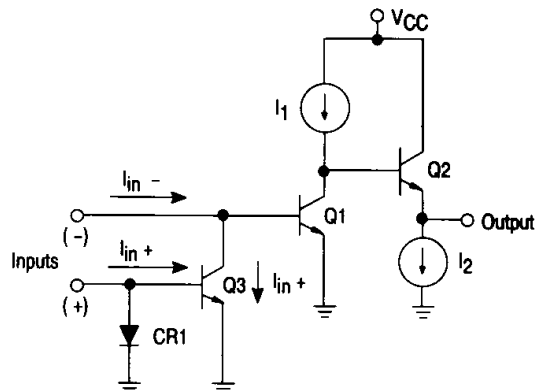

Figure 9. Obtaining A Noninverting Input



# MC3301, MC3401, LM2900, LM3900

2

## Biasing Circuitry

The circuitry common to all four amplifiers is shown in Figure 11. The purpose of this circuitry is to provide biasing voltage for the PNP and NPN current sources used in the amplifiers.

The voltage drops across diodes CR2, CR3 and CR4 are used as references. The voltage across resistor R1 is the sum of the drops across CR4 and CR3 minus the  $V_{BE}$  of Q8. The PNP current sources (Q5, ect.) are set to the magnitude  $V_{BE}/R1$  by transistor Q6. Transistor Q7 reduces base current

loading. The voltage across resistor R2 is the sum of the voltage drops across CR2, CR3 and CR4, minus the  $V_{BE}$  drops of transistor Q9 and diode CR5 thus the current set is established by CR5 in all the NPN current sources (Q10, ect.). This technique results in current source magnitudes which are relatively independent of the supply voltage. Q11 (Figure 7) provides circuit protection from signals that are negative with respect to ground.

Figure 10. A Basic Operational Amplifier

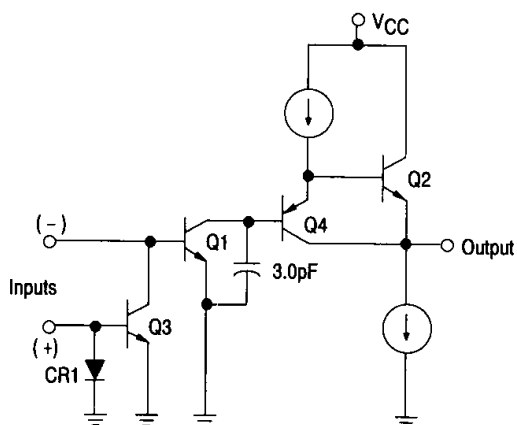
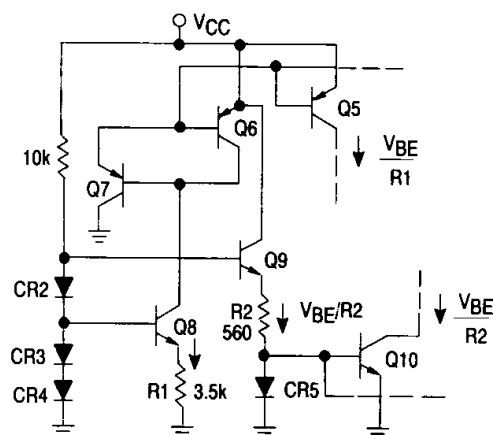

Figure 11. Biasing Circuitry



## NORMAL DESIGN PROCEDURE

### 1. Output Q-Point Biasing

A. A number of techniques may be devised to bias the quiescent output voltage to an acceptable level. However, in terms of loop gain considerations it is usually desirable to use the noninverting input to effect the biasing, as shown in Figures 12 and 13. The high impedance of the collector of the noninverting "current mirror" transistor helps to achieve the maximum loop gain for any particular configuration. It is desirable that the noninverting input current be in the 10  $\mu$ A to 200  $\mu$ A range.

### B. $V_{CC}$ Reference Voltage (see Figures 12 and 13)

The noninverting input is normally returned to the  $V_{CC}$  voltage (which should be well filtered) through a resistor ( $R_f$ ) allowing the input current, ( $I_{IN}^+$ ) to be within the range of 10  $\mu$ A to 200  $\mu$ A.

Choosing the feedback resistor ( $R_f$ ) to be equal to  $1/2 R_r$  will now bias the amplifier output DC level to approximately  $V_{CC}/2$ . This allows the maximum dynamic range of the output voltage.

### C. Reference Voltage other than $V_{CC}$ (see Figure 14)

The biasing resistor ( $R_f$ ) may be returned to a voltage ( $V_r$ ) other than  $V_{CC}$ . By setting  $R_f = R_r$  (still keeping  $I_{IN}^+$  between 10  $\mu$ A and 200  $\mu$ A) the output DC level will be equal to  $V_r$ . The expression for determining  $V_{Odc}$  is:

$$V_{Odc} = \frac{(A_i)(V_r)(R_f)}{R_r} + \left(1 - \frac{R_f}{R_r} A_i\right) \phi$$

where  $\phi$  is the  $V_{BE}$  drop of the input transistors (approximately 0.6 Vdc @ +25°C and assumed equal).  $A_i$  is the current mirror gain.

# MC3301, MC3401, LM2900, LM3900

Figure 12. Inverting Amplifier

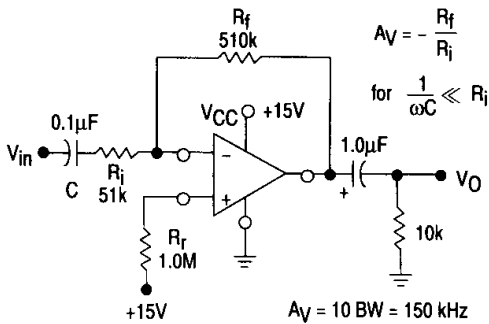
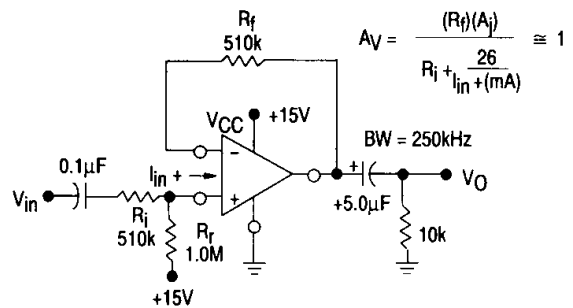

Figure 13. Noninverting Amplifier



## 2. Gain Determination

### A. Inverting Amplifier

The amplifier is normally used in the inverting mode. The input may be capacitively coupled to avoid upsetting the dc bias and the output is normally capacitively coupled to eliminate the dc voltage across the load. Note that when the output is capacitively coupled to the load, the value of  $I_{sink}$  becomes a limitation with respect to the load driving capabilities of the device is direct coupled. In this configuration, the ac gain is determined by the ratio of  $R_f$  to  $R_i$ , in the same manner as for a conventional operational amplifier:

$$A_V = \frac{R_f}{R_i}$$

The lower corner frequency is determined by the coupling capacitors to the input and load resistors. The upper corner frequency will usually be determined by the amplifier internal compensation. The amplifier unity gain bandwidth is typically be 400 kHz with 20 dB of closed-loop gain or 40 kHz with 40 dB of closed-loop gain. The exception to this occurs at low gains where the input resistor selected is large. The pole formed by the amplifier input capacitance, stray capacitance and the input resistor may occur before the closed-loop gain intercepts the open-loop response curve. The inverting input capacity is typically 3.0 pF.

Figure 14. Inverting Amplifier with Arbitrary Reference

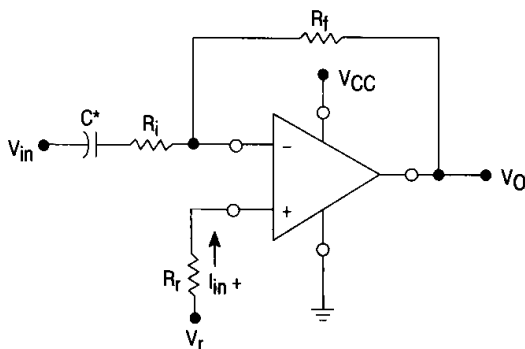

\*Select for low frequency response.

Figure 15. Inverting Amplifier with  $A_V = 100$  and  $V_r = V_{CC}$

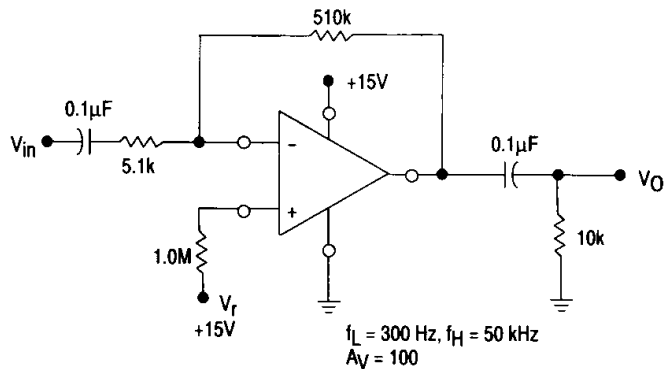

# MC3301, MC3401, LM2900, LM3900

2

## B. Noninverting Amplifier

These devices may be used in the noninverting mode (see Figure 13). The amplifier gain in this configuration is subject to the current mirror gain. In addition, the resistance of the input diode must be included in the value of the input resistor. This resistance is approximately  $\frac{26}{I_{IN}}$   $\Omega$ , where  $I_{IN}$  is input current in milliamperes. The noninverting AC gain expression is given by:

$$A_V = \frac{(R_f)(A_i)}{R_i + \frac{26}{I_{IN} + (mA)}}$$

The bandwidth of the noninverting configuration for a given  $R_f$  value is essentially independent of the gain chosen. For  $R_f = 510 \text{ k}\Omega$  the bandwidth will be in excess of 200 kHz for noninverting of 1, 10, or 100. This is a result of the loop gain remaining constant for these gains since the the input resistor is effectively isolated from the feedback loop.

Figure 16. Tachometer Circuit

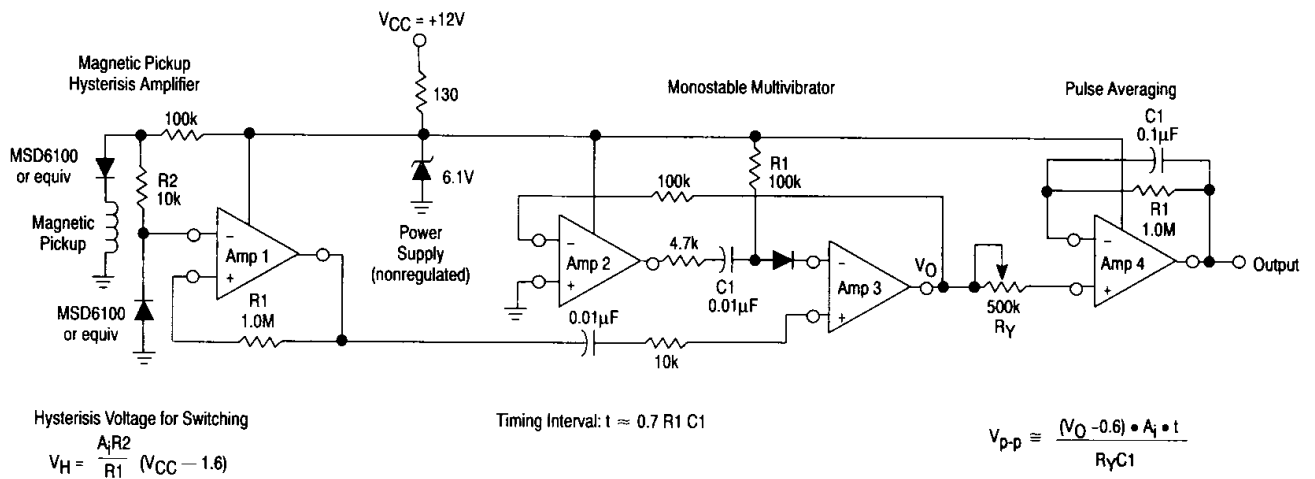
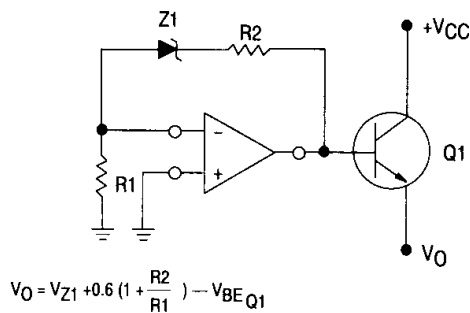
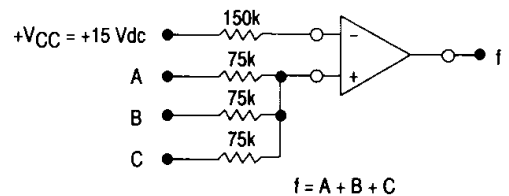

Figure 17. Voltage Regulator



Note: For positive  $T_C$  zeners  $R_2$  and  $R_1$  can be selected to give  $T_C$  output.

Figure 18. Logic "OR" Gate



# MC3301, MC3401, LM2900, LM3900

Figure 19. Logic "NAND" Gate (Large Fan-In)

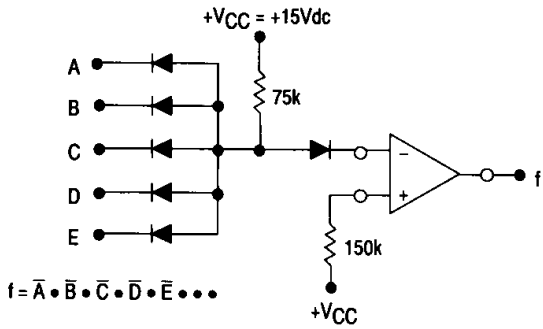

Figure 20. Logic "NOR" Gate

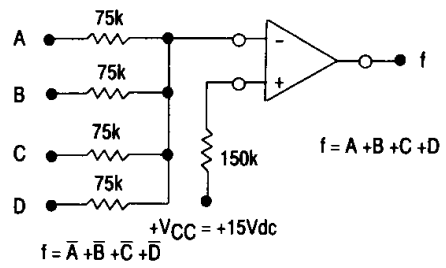

Figure 21. R-S Flip-Flop

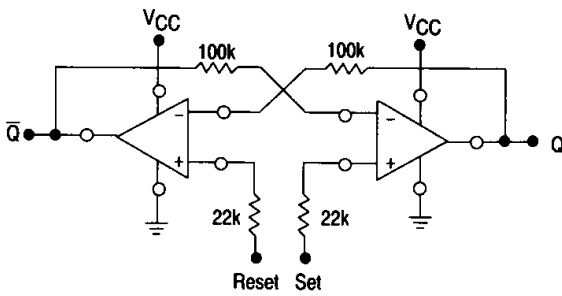

Figure 22. Astable Multivibrator

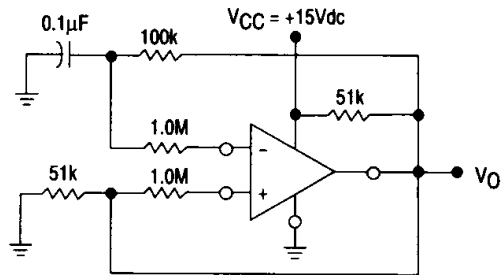

Figure 23. Positive-Edge Differentiator

Output Rise Time  $\approx 0.22$  ms  
Input Change Time Constant  $\approx 1.0$  ms

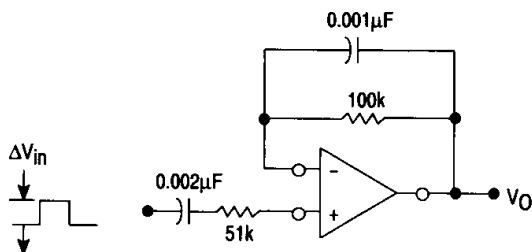
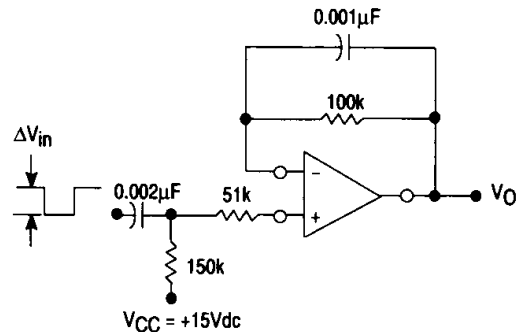

Figure 24. Negative-Edge Differentiator



$V_O(\text{dc}) = 7.0$  Vdc  
Output Rise Time  $\approx 0.22$  ms  
Input Change Time Constant  $\approx 1.0$  ms

# MC3301, MC3401, LM2900, LM3900

Figure 25. Amplifier and Driver for a 50 Ω Line

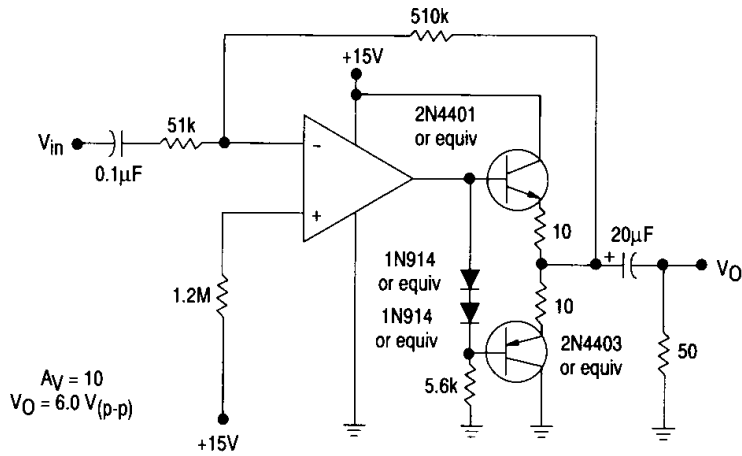

Figure 26. Basic Bandpass and Notch Filter

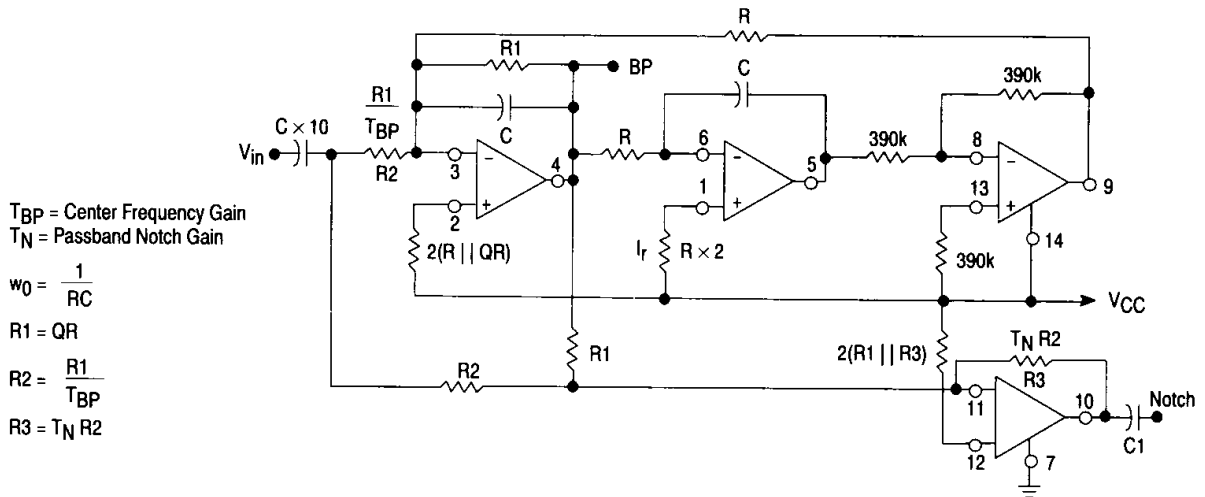
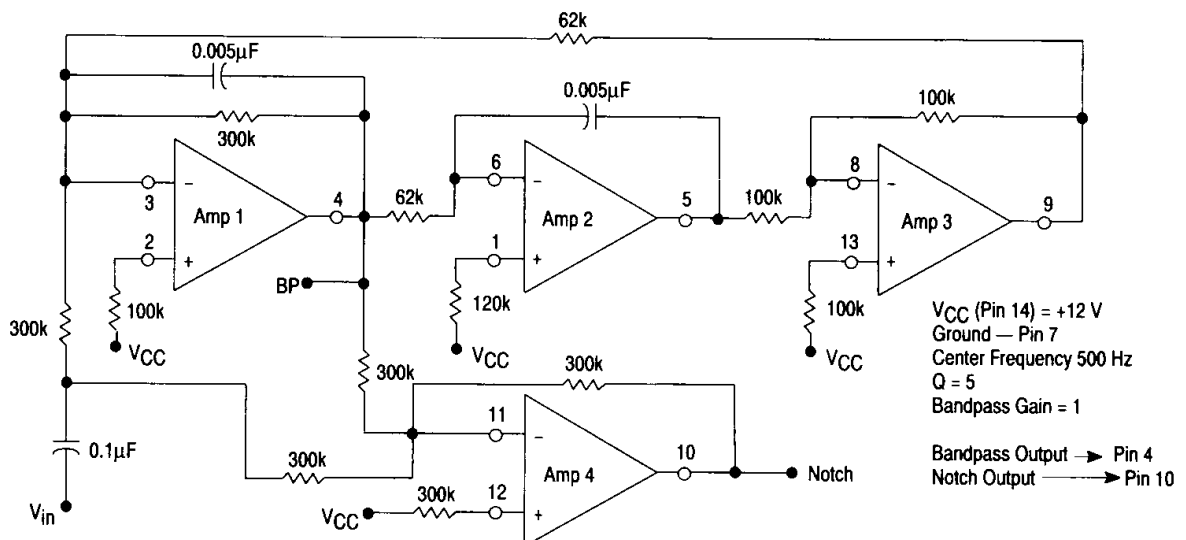
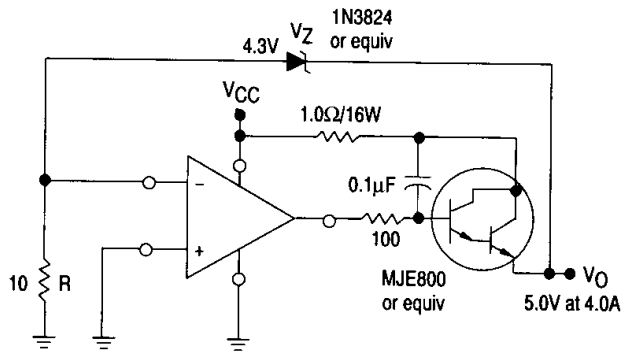

Figure 27. Bandpass and Notch Filter



# MC3301, MC3401, LM2900, LM3900

Figure 28. Voltage Regulator



$$V_O = V_Z + 0.6 \text{ Vdc}$$

- NOTES:
1. R is used to bias the zener.
  2. If the zener TC is positive, and equal in magnitude to the negative TC of the input to the operational amplifier ( $\approx 2.0 \text{ mV}^\circ\text{C}$ ), the output is zero-TC. A 7.0 V zener will give approximately zero-TC.

Figure 29. Zero Crossing Detector

